

(12) INTERNATIONAL APPLICATION PUBLISHED UNDER THE PATENT COOPERATION TREATY (PCT)

(19) World Intellectual Property Organization  
International Bureau



INTERNATIONAL PATENT CLASSIFICATION: E21B 19/16

(43) International Publication Date  
10 April 2003 (10.04.2003)

PCT

(10) International Publication Number  
WO 03/029607 A1

(51) International Patent Classification: E21B 19/16  
43/10

(72) Inventors: and

(75) Inventors/Applicants (for US only): KENDZIORA, Larry [US/US]; 6518 Williams School Court, Needville, TX 77461 (US). COOK, Robert, Lance [US/US]; 934 Caswell Court, Katy, TX 77450 (US). RING, Lev [RU/US]; 14126 Heatherhill Place, Houston, TX 77077 (US). BRISCO, David, Paul [US/US]; 405 Westridge Drive, Duncan, OK 73533 (US).

(21) International Application Number: PCT/US02/29856

(22) International Filing Date:  
19 September 2002 (19.09.2002)

(25) Filing Language: English

(74) Agents: MATTINGLY, Todd et al.; Haynes and Boone, LLP, Suite 4300, 1000 Louisiana, Houston, TX 77002-5012 (US).

(26) Publication Language: English

(30) Priority Data:  
60/326,886 3 October 2001 (03.10.2001) US

(81) Designated States (national): AE, AG, AL, AM, AT, AU, AZ, BA, BB, BG, BR, BY, BZ, CA, CH, CN, CO, CR, CU, CZ, DE, DK, DM, DZ, EC, EE, ES, FI, GB, GD, GE, GR, GM, HR, HU, ID, IL, IN, IS, JP, KE, KG, KP, KR, KZ, LC, LK, LR, LS, LT, LU, LV, MA, MD, MG, MK, MN, MW, MX, MZ, NO, NZ, PL, PT, RO, RU, SD, SE, SG, SI, SK.

(71) Applicant (for all designated States except US): ENVEN-  
TURE GLOBAL TECHNOLOGY [US/US]; 16200 A Park  
Row, Houston, TX 77084 (US).

[Continued on next page]

(54) Title: MONO-DIAMETER WELLBORE CASING

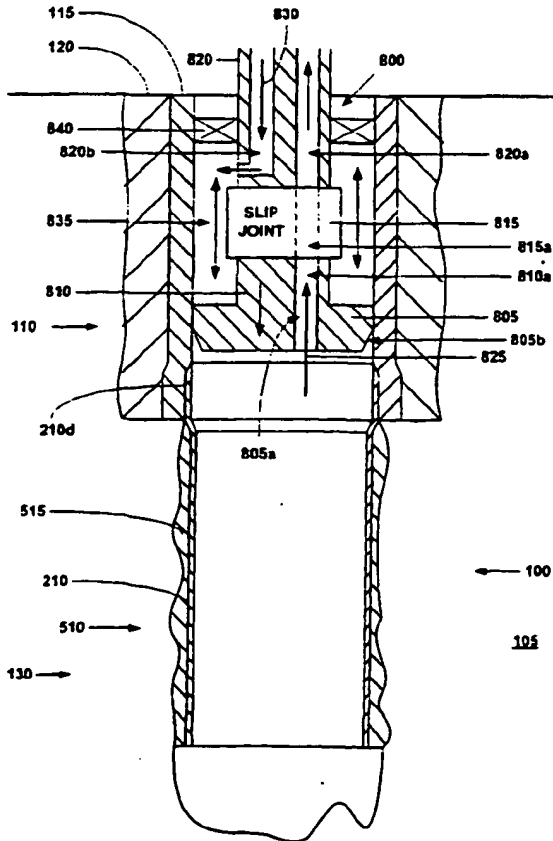

(57) Abstract: A method and system for creating a mono-diameter wellbore casing, whereby a tubular liner (210) is radially expanded into contact with a tubular casing (115) by a method of pressurizing a portion of the tubular liner (210) below a first expansion cone (805) and extruding the liner off the first expansion cone (805). The overlap between the liner and casing is then expanded and the portion of the tubular that does not overlap the casing is expanded using a second expansion cone.



WO 03/029607 A1



**MONO-DIAMETER WELLBORE CASING****Cross Reference To Related Applications**

The present application claims the benefit of the filing date of U.S. provisional patent application serial no. 60/326,886, attorney docket no. 25791.60, filed on 10/03/2001, the disclosure of which is incorporated  
 5 herein by reference.

This application is a continuation-in-part of: (1) U.S. utility application serial number 09/454,139, attorney docket number 25791.3.02, filed on 12/3/1999, which claimed the benefit of the filing date of U.S. provisional patent application serial number 60/111,293, attorney docket number 25791.3, filed on 12/7/1998, and (2) U.S. provisional application serial number 60/262,434, attorney docket number 25791.51, filed on  
 10 1/17/2001, the disclosures of which are incorporated herein by reference.

The present application is related to the following: (1) U.S. patent application serial no. 09/454,139, attorney docket no. 25791.03.02, filed on 12/3/1999, (2) U.S. patent application serial no. 09/510,913, attorney docket no. 25791.7.02, filed on 2/23/2000, (3) U.S. patent application serial no. 09/502,350, attorney docket no. 25791.8.02, filed on 2/10/2000, (4) U.S. patent application serial no. 09/440,338, attorney docket no.  
 15 25791.9.02, filed on 11/15/1999, (5) PCT patent application serial no. PCT/US01/04753, attorney docket no. 25791.10.02, filed on 2/14/2001, (6) U.S. patent application serial no. 09/523,460, attorney docket no. 25791.11.02, filed on 3/10/2000, (7) U.S. patent application serial no. 09/512,895, attorney docket no. 25791.12.02, filed on 2/24/2000, (8) U.S. patent application serial no. 09/511,941, attorney docket no. 25791.16.02, filed on 2/24/2000, (9) U.S. patent application serial no. 09/588,946, attorney docket no.  
 20 25791.17.02, filed on 6/7/2000, (10) U.S. patent application serial no. 09/559,122, attorney docket no. 25791.23.02, filed on 4/26/2000, (11) PCT patent application serial no. PCT/US00/18635, attorney docket no. 25791.25.02, filed on 7/9/2000, (12) PCT patent application serial no. PCT/US00/30022, attorney docket no. 25791.27.02, filed on 10/31/2000, (13) U.S. patent application serial no. 09/679,907, attorney docket no. 25791.34.02, filed on 10/5/2000, (14) PCT patent application serial no. PCT/US00/27645, attorney docket no.  
 25 25791.36.02, filed on 10/5/2000, (15) U.S. patent application serial no. 09/679,906, attorney docket no. 25791.37.02, filed on 10/5/2000, (16) PCT patent application serial no. PCT/US01/19014, attorney docket no. 25791.38.02, filed on 6/12/2001, (17) PCT patent application serial no. PCT/US01/41446, attorney docket no. 25791.45.02, filed on 7/28/2001, (18) PCT patent application serial no. PCT/US01/23815, attorney docket no. 25791.46.02, filed on 7/27/2001, (19) PCT patent application serial no. PCT/US01/28960, attorney docket no.  
 30 25791.47.02, filed on 9/17/2001, (20) U.S. provisional patent application serial no. 60/237,334, attorney docket no. 25791.48, filed on 10/2/2000, (21) U.S. provisional patent application serial no. 60/270,007, attorney docket no. 25791.50, filed on 2/20/2001; (22) U.S. provisional patent application serial no. 60/262,434, attorney docket no. 25791.51, filed on 1/17/2001; (23) U.S. provisional patent application serial no. 60/259,486, attorney docket no. 25791.52, filed on 1/3/2001; (24) U.S. provisional patent application serial no. 60/303,740, attorney docket  
 35 no. 25791.61, filed on 7/6/2001; (25) U.S. provisional patent application serial no. 60/313,453, attorney docket no. 25791.59, filed on 8/20/2001; (26) PCT patent application serial no. PCT/US02/24399, attorney docket no. 25791.59.02, filed on 8/1/02, (27) U.S. provisional patent application serial no. 60/317,985, attorney docket no. 25791.67, filed on 9/6/2001, (28) U.S. provisional patent application serial no. 60/318,021, attorney docket no. 25791.58, filed on 9/7/2001, (29) PCT patent application serial no. PCT/US\_\_\_\_\_, attorney

docket no. 25791.58.02 filed on 8/13/02, (30) U.S. provisional patent application serial no. 60/318,386, attorney docket no. 25791.67.02, filed on 9/10/2001 and (31) PCT patent application serial no. PCT/US \_\_\_\_\_, attorney docket no. 25791.67.03, filed on 8/14/02, the disclosures of which are incorporated herein by reference.

5

### Background of the Invention

This invention relates generally to wellbore casings, and in particular to wellbore casings that are formed using expandable tubing.

Conventionally, when a wellbore is created, a number of casings are installed in the borehole to prevent collapse of the borehole wall and to prevent undesired outflow of drilling fluid into the formation or inflow of fluid from the formation into the borehole. The borehole is drilled in intervals whereby a casing which is to be installed in a lower borehole interval is lowered through a previously installed casing of an upper borehole interval. As a consequence of this procedure the casing of the lower interval is of smaller diameter than the casing of the upper interval. Thus, the casings are in a nested arrangement with casing diameters decreasing in downward direction. Cement annuli are provided between the outer surfaces of the casings and the borehole wall to seal the casings from the borehole wall. As a consequence of this nested arrangement a relatively large borehole diameter is required at the upper part of the wellbore. Such a large borehole diameter involves increased costs due to heavy casing handling equipment, large drill bits and increased volumes of drilling fluid and drill cuttings. Moreover, increased drilling rig time is involved due to required cement pumping, cement hardening, required equipment changes due to large variations in hole diameters drilled in the course of the well, and the large volume of cuttings drilled and removed.

10  
15  
20

The present invention is directed to overcoming one or more of the limitations of the existing procedures for forming new sections of casing in a wellbore.

### Summary of the Invention

According to one aspect of the present invention, a method of creating a mono-diameter wellbore casing in a borehole located in a subterranean formation including a preexisting wellbore casing is provided that includes installing a tubular liner and a first expansion cone in the borehole, injecting a fluidic material into the borehole, pressurizing a portion of an interior region of the tubular liner below the first expansion cone, radially expanding at least a portion of the tubular liner in the borehole by extruding at least a portion of the tubular liner off of the first expansion cone, radially expanding an overlap between the preexisting wellbore casing and the tubular liner, and radially expanding the portion of the tubular liner that does not overlap with the preexisting wellbore casing using a second expansion cone.

25  
30

According to another aspect of the present invention, a system for creating a mono-diameter wellbore casing in a borehole located in a subterranean formation including a preexisting wellbore casing is provided that includes means for installing a tubular liner and a first expansion cone in the borehole, means for injecting a fluidic material into the borehole, means for pressurizing a portion of an interior region of the tubular liner below the first expansion cone, means for radially expanding at least a portion of the tubular liner in the borehole by extruding at least a portion of the tubular liner off of the first expansion cone, means for radially expanding an overlap between the preexisting wellbore casing and the tubular liner, and means for radially expanding the

35

portion of the tubular liner that does not overlap with the preexisting wellbore casing using a second expansion cone.

5 According to another aspect of the present invention, a method of creating a tubular structure having a substantially constant inside diameter is provided that includes installing a first tubular member and a first expansion cone within a second tubular member, injecting a fluidic material into the second tubular member, pressurizing a portion of an interior region of the first tubular member below the first expansion cone, radially expanding at least a portion of the first tubular member in the second tubular member by extruding at least a portion of the first tubular member off of the first expansion cone, radially expanding an overlap between the first and second tubular members, and radially expanding the portion of the first tubular member that does not overlap with the second tubular member using a second expansion cone.

10 According to another aspect of the present invention, a system for creating a tubular structure having a substantially constant inside diameter is provided that includes means for installing a first tubular member and a first expansion cone within a second tubular member, means for injecting a fluidic material into the second tubular member, means for pressurizing a portion of an interior region of the first tubular member below the first expansion cone, means for radially expanding at least a portion of the first tubular member in the second tubular member by extruding at least a portion of the first tubular member off of the first expansion cone, means for radially expanding an overlap between the first and second tubular members, and means for radially expanding the portion of the first tubular member that does not overlap with the second tubular member using a second expansion cone.

15 According to another aspect of the present invention, an apparatus is provided that includes a subterranean formation including a borehole, a wellbore casing coupled to the borehole, and a tubular liner overlappingly coupled to the wellbore casing, wherein the inside diameter of the portion of the wellbore casing that does not overlap with the tubular liner is substantially equal to the inside diameter of the tubular liner, and wherein the tubular liner is coupled to the wellbore casing by a method including installing the tubular liner and a first expansion cone in the borehole, injecting a fluidic material into the borehole, pressurizing a portion of an interior region of the tubular liner below the first expansion cone, radially expanding at least a portion of the tubular liner in the borehole by extruding at least a portion of the tubular liner off of the first expansion cone, radially expanding an overlap between the wellbore casing and the tubular liner, and radially expanding the portion of the tubular liner that does not overlap with the wellbore casing using a second expansion cone.

20 According to another aspect of the present invention, an apparatus is provided that includes a first tubular member, and a second tubular member overlappingly coupled to the first tubular member, wherein the inside diameter of the portion of the first tubular member that does not overlap with the second tubular member is substantially equal to the inside diameter of the second tubular member, and wherein the second tubular member is coupled to the first tubular member by a method that includes installing the second tubular member and a first expansion cone in the first tubular member, injecting a fluidic material into the first tubular member, pressurizing a portion of an interior region of the second tubular member below the first expansion cone, radially expanding at least a portion of the second tubular member in the first tubular member by extruding at least a portion of the tubular liner off of the first expansion cone, radially expanding an overlap between the first and

second tubular members, and radially expanding the portion of the second tubular member that does not overlap with the first tubular member using a second expansion cone.

#### Brief Description of the Drawings

5 FIG. 1 is a fragmentary cross-sectional view illustrating the drilling of a new section of a well borehole in a borehole including a preexisting section of wellbore casing.

FIG. 2 is a fragmentary cross-sectional view illustrating the placement of an embodiment of an apparatus for creating a casing within the new section of the well borehole of FIG. 1.

FIG. 3 is a fragmentary cross-sectional view illustrating the injection of a hardenable fluidic sealing material into the new section of the well borehole of FIG. 2.

10 FIG. 4 is a fragmentary cross-sectional view illustrating the injection of a fluidic material into the new section of the well borehole of FIG. 3.

FIG. 5 is a fragmentary cross-sectional view illustrating the drilling out of the cured hardenable fluidic sealing material and the shoe from the new section of the well borehole of FIG. 4.

FIG. 6 is a cross-sectional view of the well borehole of FIG. 5 following the drilling out of the shoe.

15 FIG. 7 is fragmentary cross-sectional illustration of the well borehole of FIG. 6 after positioning a shaped charge within the overlap between the expandable tubular member and the preexisting wellbore casing.

FIG. 8 is a cross-sectional illustration of the well borehole of FIG. 7 after detonating the shaped charge to plastically deform and radially expand the overlap between the expandable tubular member and the preexisting wellbore casing.

20 FIG. 9 is a fragmentary cross-sectional view of the placement and actuation of an expansion cone within the well borehole of FIG. 8 to form a mono-diameter wellbore casing.

FIG. 10 is a cross-sectional illustration of the well borehole of FIG. 9 following the formation of a mono-diameter wellbore casing.

25 FIG. 11 is a cross-sectional illustration of the well borehole of FIG. 10 following the repeated operation of the methods of FIGS. 1-10 in order to form a mono-diameter wellbore casing including a plurality of overlapping wellbore casings.

FIG. 12 is a fragmentary cross-sectional illustration of the placement of an alternative embodiment of an apparatus for forming a mono-diameter wellbore casing into the well borehole of FIG. 8.

30 FIG. 13 is a cross-sectional illustration of the well borehole of FIG. 12 following the formation of a mono-diameter wellbore casing.

FIG. 14 is a fragmentary cross-sectional illustration of the placement of an alternative embodiment of an apparatus for forming a mono-diameter wellbore casing into the well borehole of FIG. 8.

FIG. 15 is a fragmentary cross-sectional illustration of the well borehole of FIG. 14 during the injection of pressurized fluids into the well borehole.

35 FIG. 16 is a fragmentary cross-sectional illustration of the well borehole of FIG. 15 during the formation of the mono-diameter wellbore casing.

FIG. 17 is a fragmentary cross-sectional illustration of the well borehole of FIG. 16 following the formation of the mono-diameter wellbore casing.

### Detailed Description of the Illustrative Embodiments

Referring initially to FIGS. 1-10, an embodiment of an apparatus and method for forming a mono-diameter wellbore casing within a subterranean formation will now be described. As illustrated in Fig. 1, a wellbore 100 is positioned in a subterranean formation 105. The wellbore 100 includes a pre-existing cased section 110 having pre-existing wellbore casing 115 and an annular outer layer 120 of a fluidic sealing material such as, for example, cement. The wellbore 100 may be positioned in any orientation from vertical to horizontal. In several alternative embodiments, the pre-existing cased section 110 does not include the annular outer layer 120.

In order to extend the wellbore 100 into the subterranean formation 105, a drill string 125 is used in a well known manner to drill out material from the subterranean formation 105 to form a new wellbore section 130.

As illustrated in FIG. 2, an apparatus 200 for forming a wellbore casing in a subterranean formation is then positioned in the new section 130 of the wellbore 100 that includes tubular expansion cone 205 having a fluid passage 205a that supports an expandable tubular member 210 that includes a lower portion 210a, an intermediate portion 210b, an upper portion 210c, and an upper end portion 210d.

The tubular expansion cone 205 may be any number of conventional commercially available expansion cones. In several alternative embodiments, the tubular expansion cone 205 may be controllably expandable in the radial direction, for example, as disclosed in U.S. patent nos. 5,348,095, and/or 6,012,523, the disclosures of which are incorporated herein by reference.

The expandable tubular member 210 may be fabricated from any number of conventional commercially available materials such as, for example, Oilfield Country Tubular Goods (OCTG), 13 chromium steel tubing/casing, or plastic tubing/casing. In an exemplary embodiment, the expandable tubular member 210 is fabricated from OCTG in order to maximize strength after expansion. In several alternative embodiments, the expandable tubular member 210 may be solid and/or slotted. In an exemplary embodiment, the length of the expandable tubular member 210 is limited to minimize the possibility of buckling. For typical expandable tubular member 210 materials, the length of the expandable tubular member 210 is preferably limited to between about 40 to 20,000 feet in length.

The lower portion 210a of the expandable tubular member 210 preferably has a larger inside diameter than the upper portion 210c of the expandable tubular member. In an exemplary embodiment, the wall thickness of the intermediate portion 210b of the expandable tubular member 210 is less than the wall thickness of the upper portion 210c of the expandable tubular member in order to facilitate the initiation of the radial expansion process. In an exemplary embodiment, the upper end portion 210d of the expandable tubular member 210 is slotted, perforated, or otherwise modified to catch or slow down the expansion cone 205 when it completes the extrusion of expandable tubular member 210.

A shoe 215 is coupled to the lower portion 210a of the expandable tubular member. The shoe 215 includes a valveable fluid passage 220 that is preferably adapted to receive a plug, dart, or other similar element for controllably sealing the fluid passage 220. In this manner, the fluid passage 220 may be optimally sealed off by introducing a plug, dart and/or ball sealing elements into the fluid passage 240.

The shoe 215 may be any number of conventional commercially available shoes such as, for example, Super Seal II float shoe, Super Seal II Down-Jet float shoe or a guide shoe with a sealing sleeve for a latch down plug modified in accordance with the teachings of the present disclosure. In an exemplary embodiment, the shoe 215 is an aluminum down-jet guide shoe with a sealing sleeve for a latch-down plug available from Halliburton Energy Services in Dallas, TX, modified in accordance with the teachings of the present disclosure, in order to optimally guide the expandable tubular member 210 in the wellbore, optimally provide an adequate seal between the interior and exterior diameters of the overlapping joint between the tubular members, and to optimally allow the complete drill out of the shoe and plug after the completion of the cementing and expansion operations.

In an exemplary embodiment, the shoe 215 further includes one or more through and side outlet ports in fluidic communication with the fluid passage 220. In this manner, the shoe 215 optimally injects hardenable fluidic sealing material into the region outside the shoe 215 and expandable tubular member 210.

A support member 225 having fluid passages 225a and 225b is coupled to the expansion cone 205 for supporting the apparatus 200. The fluid passage 225a is preferably fluidically coupled to the fluid passage 205a. In this manner, fluidic materials may be conveyed to and from a region 230 below the expansion cone 205 and above the bottom of the shoe 215. The fluid passage 225b is preferably fluidically coupled to the fluid passage 225a and includes a conventional control valve. In this manner, during placement of the apparatus 200 within the wellbore 100, surge pressures can be relieved by the fluid passage 225b. In an exemplary embodiment, the support member 225 further includes one or more conventional centralizers (not illustrated) to help stabilize the apparatus 200.

During placement of the apparatus 200 within the wellbore 100, the fluid passage 225a is preferably selected to transport materials such as, for example, drilling mud or formation fluids at flow rates and pressures ranging from about 0 to 3,000 gallons/minute and 0 to 9,000 psi in order to minimize drag on the tubular member being run and to minimize surge pressures exerted on the wellbore 130 which could cause a loss of wellbore fluids and lead to hole collapse. During placement of the apparatus 200 within the wellbore 100, the fluid passage 225b is preferably selected to convey fluidic materials at flow rates and pressures ranging from about 0 to 3,000 gallons/minute and 0 to 9,000 psi in order to reduce the drag on the apparatus 200 during insertion into the new section 130 of the wellbore 100 and to minimize surge pressures on the new wellbore section 130.

A lower cup seal 235 is coupled to and supported by the support member 225. The lower cup seal 235 prevents foreign materials from entering the interior region of the expandable tubular member 210 adjacent to the expansion cone 205. The lower cup seal 235 may be any number of conventional commercially available cup seals such as, for example, TP cups, or Selective Injection Packer (SIP) cups modified in accordance with the teachings of the present disclosure. In an exemplary embodiment, the lower cup seal 235 is a SIP cup seal, available from Halliburton Energy Services in Dallas, TX in order to optimally block foreign material and contain a body of lubricant.

The upper cup seal 240 is coupled to and supported by the support member 225. The upper cup seal 240 prevents foreign materials from entering the interior region of the expandable tubular member 210. The upper cup seal 240 may be any number of conventional commercially available cup seals such as, for example, TP cups or SIP cups modified in accordance with the teachings of the present disclosure. In an exemplary



embodiment, the upper cup seal 240 is a SIP cup, available from Halliburton Energy Services in Dallas, TX in order to optimally block the entry of foreign materials and contain a body of lubricant.

One or more sealing members 245 are coupled to and supported by the exterior surface of the upper end portion 210d of the expandable tubular member 210. The seal members 245 preferably provide an overlapping joint between the lower end portion 115a of the casing 115 and the portion 260 of the expandable tubular member 210 to be fluidically sealed. The sealing members 245 may be any number of conventional commercially available seals such as, for example, lead, rubber, Teflon, or epoxy seals modified in accordance with the teachings of the present disclosure. In an exemplary embodiment, the sealing members 245 are molded from Stralock epoxy available from Halliburton Energy Services in Dallas, TX in order to optimally provide a load bearing interference fit between the upper end portion 210d of the expandable tubular member 210 and the lower end portion 115a of the existing casing 115.

In an exemplary embodiment, the sealing members 245 are selected to optimally provide a sufficient frictional force to support the expanded tubular member 210 from the existing casing 115. In an exemplary embodiment, the frictional force optimally provided by the sealing members 245 ranges from about 1,000 to 1,000,000 lbf in order to optimally support the expanded tubular member 210.

In an exemplary embodiment, a quantity of lubricant 250 is provided in the annular region above the expansion cone 205 within the interior of the expandable tubular member 210. In this manner, the extrusion of the expandable tubular member 210 off of the expansion cone 205 is facilitated. The lubricant 250 may be any number of conventional commercially available lubricants such as, for example, Lubriplate, chlorine based lubricants, oil based lubricants or Climax 1500 Antisieze (3100). In an exemplary embodiment, the lubricant 250 is Climax 1500 Antisieze (3100) available from Climax Lubricants and Equipment Co. in Houston, TX in order to optimally provide optimum lubrication to facilitate the expansion process.

In an exemplary embodiment, the support member 225 is thoroughly cleaned prior to assembly to the remaining portions of the apparatus 200. In this manner, the introduction of foreign material into the apparatus 200 is minimized. This minimizes the possibility of foreign material clogging the various flow passages and valves of the apparatus 200.

In an exemplary embodiment, before or after positioning the apparatus 200 within the new section 130 of the wellbore 100, a couple of wellbore volumes are circulated in order to ensure that no foreign materials are located within the wellbore 100 that might clog up the various flow passages and valves of the apparatus 200 and to ensure that no foreign material interferes with the expansion process.

As illustrated in FIG. 2, in an exemplary embodiment, during placement of the apparatus 200 within the wellbore 100, fluidic materials 255 within the wellbore that are displaced by the apparatus are conveyed through the fluid passages 220, 205a, 225a, and 225b. In this manner, surge pressures created by the placement of the apparatus within the wellbore 100 are reduced.

As illustrated in FIG. 3, the fluid passage 225b is then closed and a hardenable fluidic sealing material 305 is then pumped from a surface location into the fluid passages 225a and 205a. The material 305 then passes from the fluid passage 205a into the interior region 230 of the expandable tubular member 210 below the expansion cone 205. The material 305 then passes from the interior region 230 into the fluid passage 220. The material 305 then exits the apparatus 200 and fills an annular region 310 between the exterior of the expandable

tubular member 210 and the interior wall of the new section 130 of the wellbore 100. Continued pumping of the material 305 causes the material 305 to fill up at least a portion of the annular region 310.

5 The material 305 is preferably pumped into the annular region 310 at pressures and flow rates ranging, for example, from about 0 to 5000 psi and 0 to 1,500 gallons/min, respectively. The optimum flow rate and operating pressures vary as a function of the casing and wellbore sizes, wellbore section length, available pumping equipment, and fluid properties of the fluidic material being pumped. The optimum flow rate and operating pressure are preferably determined using conventional empirical methods.

10 The hardenable fluidic sealing material 305 may be any number of conventional commercially available hardenable fluidic sealing materials such as, for example, slag mix, cement or epoxy. In an exemplary embodiment, the hardenable fluidic sealing material 305 is a blended cement prepared specifically for the particular well section being drilled from Halliburton Energy Services in Dallas, TX in order to provide optimal support for expandable tubular member 210 while also maintaining optimum flow characteristics so as to minimize difficulties during the displacement of cement in the annular region 315. The optimum blend of the blended cement is preferably determined using conventional empirical methods. In several alternative  
15 embodiments, the hardenable fluidic sealing material 305 is compressible before, during, or after curing.

The annular region 310 preferably is filled with the material 305 in sufficient quantities to ensure that, upon radial expansion of the expandable tubular member 210, the annular region 310 of the new section 130 of the wellbore 100 will be filled with the material 305.

20 In an alternative embodiment, the injection of the material 305 into the annular region 310 is omitted. As illustrated in FIG. 4, once the annular region 310 has been adequately filled with the material 305, a plug 405, or other similar device, is introduced into the fluid passage 220, thereby fluidically isolating the interior region 230 from the annular region 310. In an exemplary embodiment, a non-hardenable fluidic material 315 is then pumped into the interior region 230 causing the interior region to pressurize. In this manner, the interior region 230 of the expanded tubular member 210 will not contain significant amounts of cured material 305. This  
25 also reduces and simplifies the cost of the entire process. Alternatively, the material 305 may be used during this phase of the process.

30 Once the interior region 230 becomes sufficiently pressurized, the expandable tubular member 210 is preferably plastically deformed, radially expanded, and extruded off of the expansion cone 205. During the extrusion process, the expansion cone 205 may be raised out of the expanded portion of the expandable tubular member 210. In an exemplary embodiment, during the extrusion process, the expansion cone 205 is raised at approximately the same rate as the expandable tubular member 210 is expanded in order to keep the expandable tubular member 210 stationary relative to the new wellbore section 130. In an alternative preferred embodiment, the extrusion process is commenced with the expandable tubular member 210 positioned above the bottom of the new wellbore section 130, keeping the expansion cone 205 stationary, and allowing the expandable tubular  
35 member 210 to extrude off of the expansion cone 205 and into the new wellbore section 130 under the force of gravity and the operating pressure of the interior region 230.

The plug 405 is preferably placed into the fluid passage 220 by introducing the plug 405 into the fluid passage 225a at a surface location in a conventional manner. The plug 405 preferably acts to fluidically isolate the hardenable fluidic sealing material 305 from the non hardenable fluidic material 315.

The plug 405 may be any number of conventional commercially available devices from plugging a fluid passage such as, for example, Multiple Stage Cementer (MSC) latch-down plug, Omega latch-down plug or three-wiper latch-down plug modified in accordance with the teachings of the present disclosure. In an exemplary embodiment, the plug 405 is a MSC latch-down plug available from Halliburton Energy Services in  
5 Dallas, TX.

After placement of the plug 405 in the fluid passage 220, the non hardenable fluidic material 315 is preferably pumped into the interior region 310 at pressures and flow rates ranging, for example, from approximately 400 to 10,000 psi and 30 to 4,000 gallons/min. In this manner, the amount of hardenable fluidic sealing material within the interior 230 of the expandable tubular member 210 is minimized. In an exemplary  
10 embodiment, after placement of the plug 405 in the fluid passage 220, the non hardenable material 315 is preferably pumped into the interior region 230 at pressures and flow rates ranging from approximately 500 to 9,000 psi and 40 to 3,000 gallons/min in order to maximize the extrusion speed.

In an exemplary embodiment, the apparatus 200 is adapted to minimize tensile, burst, and friction effects upon the expandable tubular member 210 during the expansion process. These effects will be depend  
15 upon the geometry of the expansion cone 205, the material composition of the expandable tubular member 210 and expansion cone 205, the inner diameter of the expandable tubular member, the wall thickness of the expandable tubular member, the type of lubricant, and the yield strength of the expandable tubular member. In general, the thicker the wall thickness, the smaller the inner diameter, and the greater the yield strength of the expandable tubular member 210, then the greater the operating pressures required to extrude the expandable  
20 tubular member 210 off of the expansion cone 205.

In an exemplary embodiment, the extrusion of the expandable tubular member off of the expansion cone 205 will begin when the pressure of the interior region 230 reaches, for example, approximately 500 to 9,000 psi.

During the extrusion process, the expansion cone 205 may be raised out of the expanded portion of the  
25 expandable tubular member 210 at rates ranging, for example, from about 0 to 5 ft/sec. In an exemplary embodiment, during the extrusion process, the expansion cone 205 is raised out of the expanded portion of the expandable tubular member 210 at rates ranging from about 0 to 2 ft/sec in order to minimize the time required for the expansion process while also permitting easy control of the expansion process.

When the upper end portion 210d of the expandable tubular member 210 is extruded off of the  
30 expansion cone 205, the outer surface of the upper end portion 210d of the expandable tubular member 210 will preferably contact the interior surface of the lower end portion 115a of the wellbore casing 115 to form an fluid tight overlapping joint. The contact pressure of the overlapping joint may range, for example, from approximately 50 to 20,000 psi. In an exemplary embodiment, the contact pressure of the overlapping joint ranges from approximately 400 to 10,000 psi in order to provide optimum pressure to activate the annular  
35 sealing members 245 and optimally provide resistance to axial motion to accommodate typical tensile and compressive loads.

The overlapping joint between the pre-existing wellbore casing 115 and the radially expanded expandable tubular member 210 preferably provides a gaseous and fluidic seal. In a particularly preferred

embodiment, the sealing members 245 optimally provide a fluidic and gaseous seal in the overlapping joint. In an alternative embodiment, the sealing members 245 are omitted.

5 In an exemplary embodiment, the operating pressure and flow rate of the non-hardenable fluidic material 315 is controllably ramped down when the expansion cone 205 reaches the upper end portion 210d of the expandable tubular member 210. In this manner, the sudden release of pressure caused by the complete extrusion of the expandable tubular member 210 off of the expansion cone 205 can be minimized. In an exemplary embodiment, the operating pressure is reduced in a substantially linear fashion from 100% to about 10% during the end of the extrusion process beginning when the expansion cone 205 is within about 5 feet from completion of the extrusion process.

10 Alternatively, or in combination, a shock absorber is provided in the support member 225 in order to absorb the shock caused by the sudden release of pressure. The shock absorber may, for example, be any conventional commercially available shock absorber adapted for use in wellbore operations.

Alternatively, or in combination, an expansion cone catching structure is provided in the upper end portion 210d of the expandable tubular member 210 in order to catch or at least decelerate the expansion cone 205.

15 Once the extrusion process is completed, the expansion cone 205 is removed from the wellbore 100. In an exemplary embodiment, either before or after the removal of the expansion cone 205, the integrity of the fluidic seal of the overlapping joint between the upper end portion 210d of the expandable tubular member 210 and the lower end portion 115a of the preexisting wellbore casing 115 is tested using conventional methods.

20 In an exemplary embodiment, if the fluidic seal of the overlapping joint between the upper end portion 210d of the expandable tubular member 210 and the lower end portion 115a of the casing 115 is satisfactory, then any uncured portion of the material 305 within the expanded expandable tubular member 210 is then removed in a conventional manner such as, for example, circulating the uncured material out of the interior of the expanded tubular member 210. The expansion cone 205 is then pulled out of the wellbore section 130 and a drill bit or mill is used in combination with a conventional drilling assembly 505 to drill out any hardened material 305 within the expandable tubular member 210. In an exemplary embodiment, the material 305 within the annular region 310 is then allowed to fully cure.

25 As illustrated in Fig. 5, preferably any remaining cured material 305 within the interior of the expanded tubular member 210 is then removed in a conventional manner using a conventional drill string 505. The resulting new section of casing 510 preferably includes the expanded tubular member 210 and an outer annular layer 515 of the cured material 305.

30 As illustrated in FIG. 6, the bottom portion of the apparatus 200 including the shoe 215 and dart 405 may then be removed by drilling out the shoe 215 and dart 405 using conventional drilling methods.

35 As illustrated in FIG. 7, an apparatus 600 for radially expanding and plastically deforming the overlap between the lower portion of the preexisting wellbore casing 115 and the upper portion 210d of the expandable tubular member 210 may then be positioned within the borehole 110 that includes a shaped charge 605 that is coupled to an end of a tubular member 610. In an exemplary embodiment, the shaped charge 605 is positioned within the overlap between the lower portion of the preexisting wellbore casing 115 and the upper portion 210d of the expandable tubular member 210.

As illustrated in FIG. 8, the shaped charge 605 is then detonated in a conventional manner to plastically deform and radially expand the overlap between the lower portion of the preexisting wellbore casing 115 and the upper portion 210d of the expanded tubular member 210. As a result, the inside diameter of the upper portion 210d of the expanded tubular member 210 is substantially equal to the inside diameter of the portion of the preexisting wellbore casing 115 that does not overlap with the upper portion of the expanded tubular member. In several alternative embodiments, one or more conventional devices for generating impulsive radially directed forces may be substituted for, or used in combination with, the shaped charge 605.

As illustrated in FIG. 9, an apparatus 700 for forming a mono-diameter wellbore casing is then positioned within the wellbore casing 115 proximate upper end 210d of the expandable tubular member 210 that includes a tubular expansion cone 705 coupled to an end of a tubular support member 710. In an exemplary embodiment, the outside diameter of the tubular expansion cone 705 is substantially equal to the inside diameter of the wellbore casing 115. The tubular expansion cone 705 and the tubular support member 710 together define a fluid passage 715 for conveying fluidic materials 720 out of the wellbore 100 that are displaced by the placement and operation of the tubular expansion cone 705.

The tubular expansion cone 705 is then driven downward using the support member 710 in order to radially expand and plastically deform the portion of the expandable tubular member 210 that does not overlap with the wellbore casing 115. In this manner, as illustrated in FIG. 10, a mono-diameter wellbore casing is formed that includes the overlapping wellbore casings 115 and 210. In several alternative embodiments, the secondary radial expansion process illustrated in FIGS. 9 and 10 is performed before, during, or after the material 515 fully cures. In several alternative embodiments, a conventional expansion device including rollers may be substituted for, or used in combination with, the apparatus 700. In an exemplary embodiment, the downward displacement of the tubular expansion cone 705 also at least partially radially expands and plastically deforms the portions of the pre-existing wellbore casing 115 and the upper portion 210d of the expandable tubular member that overlap with one another,

More generally, as illustrated in FIG. 11, the method of FIGS. 1-10 is repeatedly performed in order to provide a mono-diameter wellbore casing that includes overlapping wellbore casings 115 and 210a-210e. The wellbore casings 115, and 210a-210e preferably include outer annular layers of fluidic sealing material. In this manner, a mono-diameter wellbore casing may be formed within the subterranean formation that extends for tens of thousands of feet. More generally still, the teachings of FIGS. 1-11 may be used to form a mono-diameter wellbore casing, a pipeline, a structural support, or a tunnel within a subterranean formation at any orientation from the vertical to the horizontal.

In an exemplary embodiment, the formation of the mono-diameter wellbore casing, as illustrated in FIGS. 1-11, is further provided as disclosed in one or more of the following: (1) U.S. patent application serial no. 09/454,139, attorney docket no. 25791.03.02, filed on 12/3/1999, (2) U.S. patent application serial no. 09/510,913, attorney docket no. 25791.7.02, filed on 2/23/2000, (3) U.S. patent application serial no. 09/502,350, attorney docket no. 25791.8.02, filed on 2/10/2000, (4) U.S. patent application serial no. 09/440,338, attorney docket no. 25791.9.02, filed on 11/15/1999, (5) PCT patent application serial no. PCT/US01/04753, attorney docket no. 25791.10.02, filed on 2/14/2001, (6) U.S. patent application serial no. 09/523,460, attorney docket no. 25791.11.02, filed on 3/10/2000, (7) U.S. patent application serial no.

- 09/512,895, attorney docket no. 25791.12.02, filed on 2/24/2000, (8) U.S. patent application serial no.  
 09/511,941, attorney docket no. 25791.16.02, filed on 2/24/2000, (9) U.S. patent application serial no.  
 09/588,946, attorney docket no. 25791.17.02, filed on 6/7/2000, (10) U.S. patent application serial no.  
 09/559,122, attorney docket no. 25791.23.02, filed on 4/26/2000, (11) PCT patent application serial no.  
 5 PCT/US00/18635, attorney docket no. 25791.25.02, filed on 7/9/2000, (12) PCT patent application serial no.  
 PCT/US00/30022, attorney docket no. 25791.27.02, filed on 10/31/2000, (13) U.S. patent application serial no.  
 09/679,907, attorney docket no. 25791.34.02, filed on 10/5/2000, (14) PCT patent application serial no.  
 PCT/US00/27645, attorney docket no. 25791.36.02, filed on 10/5/2000, (15) U.S. patent application serial no.  
 09/679,906, attorney docket no. 25791.37.02, filed on 10/5/2000, (16) PCT patent application serial no.  
 10 PCT/US01/19014, attorney docket no. 25791.38.02, filed on 6/12/2001, (17) PCT patent application serial no.  
 PCT/US01/41446, attorney docket no. 25791.45.02, filed on 7/28/2001, (18) PCT patent application serial no.  
 PCT/US01/23815, attorney docket no. 25791.46.02, filed on 7/27/2001, (19) PCT patent application serial no.  
 PCT/US01/28960, attorney docket no. 25791.47.02, filed on 9/17/2001, (20) U.S. provisional patent application  
 serial no. 60/237,334, attorney docket no. 25791.48, filed on 10/2/2000, (21) U.S. provisional patent application  
 15 serial no. 60/270,007, attorney docket no. 25791.50, filed on 2/20/2001; (22) U.S. provisional patent application  
 serial no. 60/262,434, attorney docket no. 25791.51, filed on 1/17/2001; (23) U.S. provisional patent application  
 serial no. 60/259,486, attorney docket no. 25791.52, filed on 1/3/2001; (24) U.S. provisional patent application  
 serial no. 60/303,740, attorney docket no. 25791.61, filed on 7/6/2001; (25) U.S. provisional patent application  
 serial no. 60/313,453, attorney docket no. 25791.59, filed on 8/20/2001; (26) PCT patent application serial no.  
 20 PCT/US02/24399, attorney docket no. 25791.59.02, filed on 8/1/02, (27) U.S. provisional patent application  
 serial no. 60/317,985, attorney docket no. 25791.67, filed on 9/6/2001, (28) U.S. provisional patent application  
 serial no. 60/318,021, attorney docket no. 25791.58, filed on 9/7/2001, (29) PCT patent application serial no.  
 PCT/US\_\_\_\_\_, attorney docket no. 25791.58.02 filed on 8/13/02, (30) U.S. provisional patent  
 application serial no. 60/318,386, attorney docket no. 25791.67.02, filed on 9/10/2001 and (31) PCT patent  
 25 application serial no. PCT/US\_\_\_\_\_, attorney docket no. 25791.67.03, filed on 8/14/02, the  
 disclosures of which are incorporated herein by reference.

In an alternative embodiment, the fluid passage 220 in the shoe 215 is omitted. In this manner, the  
 pressurization of the region 230 is simplified. In an alternative embodiment, the annular body 515 of the fluidic  
 sealing material is formed using conventional methods of injecting a hardenable fluidic sealing material into the  
 30 annular region 310.

In an alternative embodiment of the apparatus 700, the fluid passage 715 is omitted. In this manner, in  
 an exemplary embodiment, the region of the wellbore 100 below the expansion cone 705 is pressurized and one  
 or more regions of the subterranean formation 105 are fractured to enhance the oil and/or gas recovery process.

Referring to FIGS. 12-13, in an alternative embodiment, an apparatus 800 for forming a mono-diameter  
 35 wellbore casing is positioned within the wellbore casing 115 that includes a tubular expansion cone 805 that  
 defines a fluid passage 805a that is coupled to a support member 810.

The tubular expansion cone 805 preferably further includes a conical outer surface 805b for radially  
 expanding and plastically deforming the portion of the expandable tubular member 210 that does not overlap  
 with the wellbore casing 115. In an exemplary embodiment, the outside diameter of the tubular expansion cone

805 is substantially equal to the inside diameter of the portion of the pre-existing wellbore casing 115 that does not overlap with the expandable tubular member 210.

5 The support member 810 is coupled to a slip joint 815, and the slip joint is coupled to a support member 820. As will be recognized by persons having ordinary skill in the art, a slip joint permits relative movement between objects. Thus, in this manner, the expansion cone 805 and support member 810 may be displaced in the longitudinal direction relative to the support member 820. In an exemplary embodiment, the slip joint 810 permits the expansion cone 805 and support member 810 to be displaced in the longitudinal direction relative to the support member 820 for a distance greater than or equal to the axial length of the expandable tubular member 210. In this manner, the expansion cone 805 may be used to plastically deform and radially expand the portion of the expandable tubular member 210 that does not overlap with the pre-existing wellbore casing 115 without having to reposition the support member 820.

10 The slip joint 815 may be any number of conventional commercially available slip joints that include a fluid passage for conveying fluidic materials through the slip joint. In an exemplary embodiment, the slip joint 815 is a pumper sub commercially available from Bowen Oil Tools in order to optimally provide elongation of the drill string.

15 The support member 810, slip joint 815, and support member 820 further include fluid passages 810a, 815a, and 820a, respectively, that are fluidically coupled to the fluid passage 805a. During operation, the fluid passages 805a, 810a, 815a, and 820a preferably permit fluidic materials 825 displaced by the expansion cone 805 to be conveyed to a location above the apparatus 800. In this manner, operating pressures within the subterranean formation 105 below the expansion cone are minimized.

20 The support member 820 further preferably includes a fluid passage 820b that permits fluidic materials 830 to be conveyed into an annular region 835 surrounding the support member 810, the slip joint 815, and the support member 820 and bounded by the expansion cone 805 and a conventional packer 840 that is coupled to the support member 820. In this manner, the annular region 835 may be pressurized by the injection of the fluids 830 thereby causing the expansion cone 805 to be displaced in the longitudinal direction relative to the support member 820 to thereby plastically deform and radially expand the portion of the expandable tubular member 210 that does not overlap with the pre-existing wellbore casing 115.

25 During operation, as illustrated in FIG. 10, in an exemplary embodiment, the apparatus 800 is positioned within the preexisting casing 115 with the bottom surface of the expansion cone 805 proximate the top of the expandable tubular member 210. During placement of the apparatus 800 within the preexisting casing 115, fluidic materials 825 within the casing are conveyed out of the casing through the fluid passages 805a, 810a, 815a, and 820a. In this manner, surge pressures within the wellbore 100 are minimized.

30 The packer 840 is then operated in a well-known manner to fluidically isolate the annular region 835 from the annular region above the packer. The fluidic material 830 is then injected into the annular region 835 using the fluid passage 820b. Continued injection of the fluidic material 830 into the annular region 835 preferably pressurizes the annular region and thereby causes the expansion cone 805 and support member 810 to be displaced in the longitudinal direction relative to the support member 820.

35 As illustrated in FIG. 13, in an exemplary embodiment, the longitudinal displacement of the expansion cone 805 in turn plastically deforms and radially expands the portion of the expandable tubular member 210 that

does not overlap the pre-existing wellbore casing 115. In this manner, a minimum diameter wellbore casing is formed that includes the overlapping wellbore casings 115 and 210. The apparatus 800 may then be removed from the wellbore 100 by releasing the packer 840 from engagement with the wellbore casing 115, and lifting the apparatus 800 out of the wellbore 100. In an exemplary embodiment, the downward longitudinal displacement of the expansion cone 805 also at least partially radially expands and plastically deforms the portions of the pre-existing wellbore casing 115 and the upper portion 210d of the expandable tubular member 210 that overlap with one another.

In an alternative embodiment of the apparatus 800, the fluid passage 820b is provided within the packer 840 in order to enhance the operation of the apparatus 800.

In an alternative embodiment of the apparatus 800, the fluid passages 805a, 810a, 815a, and 820a are omitted. In this manner, in an exemplary embodiment, the region of the wellbore 100 below the expansion cone 805 is pressurized and one or more regions of the subterranean formation 105 are fractured to enhance the oil and/or gas recovery process.

Referring to FIGS. 14-17, in an alternative embodiment, an apparatus 900 is positioned within the wellbore casing 115 that includes an expansion cone 905 having a fluid passage 905a that is releasably coupled to a releasable coupling 910 having fluid passage 910a.

The fluid passage 905a is preferably adapted to receive a conventional ball, plug, or other similar device for sealing off the fluid passage. The expansion cone 905 further includes a conical outer surface 905b for radially expanding and plastically deforming the portion of the expandable tubular member 210 that does not overlap the pre-existing wellbore casing 115. In an exemplary embodiment, the outside diameter of the expansion cone 905 is substantially equal to the inside diameter of the portion of the pre-existing wellbore casing 115 that does not overlap with the upper end 210d of the expandable tubular member 210.

The releasable coupling 910 may be any number of conventional commercially available releasable couplings that include a fluid passage for conveying fluidic materials through the releasable coupling. In an exemplary embodiment, the releasable coupling 910 is a safety joint commercially available from Halliburton in order to optimally release the expansion cone 905 from the support member 915 at a predetermined location.

A support member 915 is coupled to the releasable coupling 910 that includes a fluid passage 915a. The fluid passages 905a, 910a and 915a are fluidically coupled. In this manner, fluidic materials may be conveyed into and out of the wellbore 100.

A packer 920 is movably and sealingly coupled to the support member 915. The packer may be any number of conventional packers. In an exemplary embodiment, the packer 920 is a commercially available burst preventer (BOP) in order to optimally provide a sealing member.

During operation, as illustrated in FIG. 14, in an exemplary embodiment, the apparatus 900 is positioned within the preexisting casing 115 with the bottom surface of the expansion cone 905 proximate the top of the expandable tubular member 210. During placement of the apparatus 900 within the preexisting casing 115, fluidic materials 925 within the casing are conveyed out of the casing through the fluid passages 905a, 910a, and 915a. In this manner, surge pressures within the wellbore 100 are minimized. The packer 920 is then operated in a well-known manner to fluidically isolate a region 930 within the casing 115 between the expansion cone 905 and the packer 920 from the region above the packer.



In an exemplary embodiment, as illustrated in FIG. 15, the releasable coupling 910 is then released from engagement with the expansion cone 905 and the support member 915 is moved away from the expansion cone. A fluidic material 935 may then be injected into the region 930 through the fluid passages 910a and 915a.

5 The fluidic material 935 may then flow into the region of the wellbore 100 below the expansion cone 905 through the valveable passage 905b. Continued injection of the fluidic material 935 may thereby pressurize and fracture regions of the formation 105 below the expandable tubular member 210. In this manner, the recovery of oil and/or gas from the formation 105 may be enhanced.

In an exemplary embodiment, as illustrated in FIG. 16, a plug, ball, or other similar valve device 940 may then be positioned in the valveable passage 905a by introducing the valve device into the fluidic material 10 935. In this manner, the region 930 may be fluidically isolated from the region below the expansion cone 905. Continued injection of the fluidic material 935 may then pressurize the region 930 thereby causing the expansion cone 905 to be displaced in the longitudinal direction.

In an exemplary embodiment, as illustrated in FIG. 17, the longitudinal displacement of the expansion cone 905 plastically deforms and radially expands the portion of the expandable tubular 210 that does not 15 overlap with the pre-existing wellbore casing 115. In this manner, a mono-diameter wellbore casing is formed that includes the pre-existing wellbore casing 115 and the expandable tubular member 210. Upon completing the radial expansion process, the support member 915 may be moved toward the expansion cone 905 and the expansion cone may be re-coupled to the releasable coupling device 910. The packer 920 may then be decoupled from the wellbore casing 115, and the expansion cone 905 and the remainder of the apparatus 900 20 may then be removed from the wellbore 100. In an exemplary embodiment, the downward longitudinal displacement of the expansion cone 905 also at least partially plastically deforms and radially expands the portions of the pre-existing wellbore casing 115 and the upper portion 210d of the expandable tubular member 210 that overlap with one another.

In an exemplary embodiment, the displacement of the expansion cone 905 also pressurizes the region 25 within the expandable tubular member 210 below the expansion cone. In this manner, the subterranean formation surrounding the expandable tubular member 210 may be elastically or plastically compressed thereby enhancing the structural properties of the formation.

A method of creating a mono-diameter wellbore casing in a borehole located in a subterranean formation including a preexisting wellbore casing has also been described that includes installing a tubular liner 30 and a first expansion cone in the borehole, injecting a fluidic material into the borehole, pressurizing a portion of an interior region of the tubular liner below the first expansion cone, radially expanding at least a portion of the tubular liner in the borehole by extruding at least a portion of the tubular liner off of the first expansion cone, radially expanding an overlap between the preexisting wellbore casing and the tubular liner, and radially expanding the portion of the tubular liner that does not overlap with the preexisting wellbore casing using a 35 second expansion cone. In an exemplary embodiment, radially expanding the overlap between the preexisting wellbore casing and the tubular liner includes impulsively applying outwardly directed radial forces to the interior of the overlap between the preexisting wellbore casing and the tubular liner. In an exemplary embodiment, impulsively applying outwardly directed radial forces to the interior of the overlap between the preexisting wellbore casing and the tubular liner includes detonating a shaped charge within the overlap between

the preexisting wellbore casing and the tubular liner. In an exemplary embodiment, radially expanding the overlap between the preexisting wellbore casing and the tubular liner further includes displacing the second expansion cone in a longitudinal direction, and permitting fluidic materials displaced by the second expansion cone to be removed. In an exemplary embodiment, displacing the second expansion cone in a longitudinal

5 direction includes applying fluid pressure to the second expansion cone. In an exemplary embodiment, radially expanding the overlap between the tubular liner and the preexisting wellbore casing using the second expansion cone further includes displacing the second expansion cone in a longitudinal direction, and compressing at least a portion of the subterranean formation using fluid pressure. In an exemplary embodiment, displacing the second expansion cone in a longitudinal direction includes applying fluid pressure to the second expansion cone.

10 In an exemplary embodiment, radially expanding the portion of the tubular liner that does not overlap with the preexisting wellbore casing using the second expansion cone includes displacing the second expansion cone in a longitudinal direction, and permitting fluidic materials displaced by the second expansion cone to be removed. In an exemplary embodiment, displacing the second expansion cone in the longitudinal direction includes applying fluid pressure to the second expansion cone. In an exemplary embodiment, radially expanding the

15 portion of the tubular liner that does not overlap with the preexisting wellbore casing using the second expansion cone includes displacing the second expansion cone in a longitudinal direction, and compressing at least a portion of the subterranean formation using fluid pressure. In an exemplary embodiment, displacing the second expansion cone in the longitudinal direction includes applying fluid pressure to the second expansion cone. In an exemplary embodiment, the method further includes injecting a hardenable fluidic sealing material into an

20 annulus between the tubular liner and the borehole.

A system for creating a mono-diameter wellbore casing in a borehole located in a subterranean formation including a preexisting wellbore casing has also been described that includes means for installing a tubular liner and a first expansion cone in the borehole, means for injecting a fluidic material into the borehole, means for pressurizing a portion of an interior region of the tubular liner below the first expansion cone, means

25 for radially expanding at least a portion of the tubular liner in the borehole by extruding at least a portion of the tubular liner off of the first expansion cone, means for radially expanding an overlap between the preexisting wellbore casing and the tubular liner, and means for radially expanding the portion of the tubular liner that does not overlap with the preexisting wellbore casing using a second expansion cone. In an exemplary embodiment, the means for radially expanding the overlap between the preexisting wellbore casing and the tubular liner

30 includes means for impulsively applying outwardly directed radial forces to the interior of the overlap between the preexisting wellbore casing and the tubular liner. In an exemplary embodiment, the means for impulsively applying outwardly directed radial forces to the interior of the overlap between the preexisting wellbore casing and the tubular liner includes means for detonating a shaped charge within the overlap between the preexisting wellbore casing and the tubular liner. In an exemplary embodiment, the means for radially expanding the

35 overlap between the preexisting wellbore casing and the tubular liner further includes displacing the second expansion cone in a longitudinal direction, and permitting fluidic materials displaced by the second expansion cone to be removed. In an exemplary embodiment, the means for displacing the second expansion cone in a longitudinal direction includes means for applying fluid pressure to the second expansion cone. In an exemplary embodiment, the means for radially expanding the overlap between the tubular liner and the preexisting wellbore

casing using the second expansion cone further includes means for displacing the second expansion cone in a longitudinal direction, and means for compressing at least a portion of the subterranean formation using fluid pressure. In an exemplary embodiment, the means for displacing the second expansion cone in a longitudinal direction includes means for applying fluid pressure to the second expansion cone. In an exemplary  
5 embodiment, the means for radially expanding the portion of the tubular liner that does not overlap with the preexisting wellbore casing using the second expansion cone includes means for displacing the second expansion cone in a longitudinal direction, and means for permitting fluidic materials displaced by the second expansion cone to be removed. In an exemplary embodiment, the means for displacing the second expansion cone in the longitudinal direction includes means for applying fluid pressure to the second expansion cone. In an exemplary  
10 embodiment, the means for radially expanding the portion of the tubular liner that does not overlap with the preexisting wellbore casing using the second expansion cone includes means for displacing the second expansion cone in a longitudinal direction, and means for compressing at least a portion of the subterranean formation using fluid pressure. In an exemplary embodiment, the means for displacing the second expansion cone in the longitudinal direction includes means for applying fluid pressure to the second expansion cone. In an exemplary  
15 embodiment, the system further includes means for injecting a hardenable fluidic sealing material into an annulus between the tubular liner and the borehole.

A method of creating a tubular structure having a substantially constant inside diameter has also been described that includes installing a first tubular member and a first expansion cone within a second tubular member, injecting a fluidic material into the second tubular member, pressurizing a portion of an interior region  
20 of the first tubular member below the first expansion cone, radially expanding at least a portion of the first tubular member in the second tubular member by extruding at least a portion of the first tubular member off of the first expansion cone, radially expanding an overlap between the first and second tubular members, and radially expanding the portion of the first tubular member that does not overlap with the second tubular member using a second expansion cone. In an exemplary embodiment, radially expanding the overlap between the first  
25 and second tubular members includes impulsively applying outwardly directed radial forces to the interior of the overlap between the first and second tubular members. In an exemplary embodiment, impulsively applying outwardly directed radial forces to the interior of the overlap between the first and second tubular members includes detonating a shaped charge within the overlap between the first and second tubular members. In an exemplary embodiment, radially expanding the overlap between the first and second tubular members further  
30 includes displacing the second expansion cone in a longitudinal direction, and permitting fluidic materials displaced by the second expansion cone to be removed. In an exemplary embodiment, displacing the second expansion cone in a longitudinal direction includes applying fluid pressure to the second expansion cone. In an exemplary embodiment, radially expanding the overlap between the first and second tubular members using the second expansion cone further includes displacing the second expansion cone in a longitudinal direction, and  
35 compressing at least a portion of the subterranean formation using fluid pressure. In an exemplary embodiment, displacing the second expansion cone in a longitudinal direction includes applying fluid pressure to the second expansion cone. In an exemplary embodiment, radially expanding the portion of the first tubular member that does not overlap with the second tubular member using the second expansion cone includes displacing the second expansion cone in a longitudinal direction, and permitting fluidic materials displaced by the second

expansion cone to be removed. In an exemplary embodiment, displacing the second expansion cone in the longitudinal direction includes applying fluid pressure to the second expansion cone.

A system for creating a tubular structure having a substantially constant inside diameter has also been described that includes means for installing a first tubular member and a first expansion cone within a second tubular member, means for injecting a fluidic material into the second tubular member, means for pressurizing a portion of an interior region of the first tubular member below the first expansion cone, means for radially expanding at least a portion of the first tubular member in the second tubular member by extruding at least a portion of the first tubular member off of the first expansion cone, means for radially expanding an overlap between the first and second tubular members, and means for radially expanding the portion of the first tubular member that does not overlap with the second tubular member using a second expansion cone. In an exemplary embodiment, the means for radially expanding the overlap between the first and second tubular members includes means for impulsively applying outwardly directed radial forces to the interior of the overlap between the first and second tubular members. In an exemplary embodiment, the means for impulsively applying outwardly directed radial forces to the interior of the overlap between the first and second tubular members includes means for detonating a shaped charge within the overlap between the first and second tubular members. In an exemplary embodiment, the means for radially expanding the overlap between the first and second tubular members further includes means for displacing the second expansion cone in a longitudinal direction, and means for permitting fluidic materials displaced by the second expansion cone to be removed. In an exemplary embodiment, the means for displacing the second expansion cone in a longitudinal direction includes means for applying fluid pressure to the second expansion cone. In an exemplary embodiment, the means for radially expanding the overlap between the first and second tubular members using the second expansion cone further includes means for displacing the second expansion cone in a longitudinal direction, and means for compressing at least a portion of the subterranean formation using fluid pressure. In an exemplary embodiment, the means for displacing the second expansion cone in a longitudinal direction includes means for applying fluid pressure to the second expansion cone. In an exemplary embodiment, the means for radially expanding the portion of the first tubular member that does not overlap with the second tubular member using the second expansion cone includes means for displacing the second expansion cone in a longitudinal direction, and means for permitting fluidic materials displaced by the second expansion cone to be removed. In an exemplary embodiment, the means for displacing the second expansion cone in the longitudinal direction includes means for applying fluid pressure to the second expansion cone.

An apparatus has also been described that includes a subterranean formation including a borehole, a wellbore casing coupled to the borehole, and a tubular liner overlappingly coupled to the wellbore casing, wherein the inside diameter of the portion of the wellbore casing that does not overlap with the tubular liner is substantially equal to the inside diameter of the tubular liner, and wherein the tubular liner is coupled to the wellbore casing by a method including installing the tubular liner and a first expansion cone in the borehole, injecting a fluidic material into the borehole, pressurizing a portion of an interior region of the tubular liner below the first expansion cone, radially expanding at least a portion of the tubular liner in the borehole by extruding at least a portion of the tubular liner off of the first expansion cone, radially expanding an overlap between the wellbore casing and the tubular liner, and radially expanding the portion of the tubular liner that

does not overlap with the wellbore casing using a second expansion cone. In an exemplary embodiment, radially expanding the overlap between the preexisting wellbore casing and the tubular liner includes impulsively applying outwardly directed radial forces to the interior of the overlap between the wellbore casing and the tubular liner. In an exemplary embodiment, impulsively applying outwardly directed radial forces to the interior of the overlap between the wellbore casing and the tubular liner includes detonating a shaped charge within the overlap between the wellbore casing and the tubular liner. In an exemplary embodiment, radially expanding the overlap between the wellbore casing and the tubular liner further includes displacing the second expansion cone in a longitudinal direction, and permitting fluidic materials displaced by the second expansion cone to be removed. In an exemplary embodiment, displacing the second expansion cone in a longitudinal direction includes applying fluid pressure to the second expansion cone. In an exemplary embodiment, radially expanding the overlap between the tubular liner and the wellbore casing using the second expansion cone further includes displacing the second expansion cone in a longitudinal direction, and compressing at least a portion of the subterranean formation using fluid pressure. In an exemplary embodiment, displacing the second expansion cone in a longitudinal direction includes applying fluid pressure to the second expansion cone. In an exemplary embodiment, radially expanding the portion of the tubular liner that does not overlap with the wellbore casing using the second expansion cone includes displacing the second expansion cone in a longitudinal direction, and permitting fluidic materials displaced by the second expansion cone to be removed. In an exemplary embodiment, displacing the second expansion cone in the longitudinal direction includes applying fluid pressure to the second expansion cone. In an exemplary embodiment, radially expanding the portion of the tubular liner that does not overlap with the wellbore casing using the second expansion cone includes displacing the second expansion cone in a longitudinal direction, and compressing at least a portion of the subterranean formation using fluid pressure. In an exemplary embodiment, displacing the second expansion cone in the longitudinal direction includes applying fluid pressure to the second expansion cone. In an exemplary embodiment, the apparatus further includes injecting a hardenable fluidic sealing material into an annulus between the tubular liner and the borehole.

An apparatus has also been described that includes a first tubular member, and a second tubular member overlappingly coupled to the first tubular member, wherein the inside diameter of the portion of the first tubular member that does not overlap with the second tubular member is substantially equal to the inside diameter of the second tubular member, and wherein the second tubular member is coupled to the first tubular member by a method that includes installing the second tubular member and a first expansion cone in the first tubular member, injecting a fluidic material into the first tubular member, pressurizing a portion of an interior region of the second tubular member below the first expansion cone, radially expanding at least a portion of the second tubular member in the first tubular member by extruding at least a portion of the tubular liner off of the first expansion cone, radially expanding an overlap between the first and second tubular members, and radially expanding the portion of the second tubular member that does not overlap with the first tubular member using a second expansion cone. In an exemplary embodiment, radially expanding the overlap between the first and second tubular members includes impulsively applying outwardly directed radial forces to the interior of the overlap between the first and second tubular members. In an exemplary embodiment, impulsively applying outwardly directed radial forces to the interior of the overlap between the first and second tubular members

includes detonating a shaped charge within the overlap between the first and second tubular members. In an exemplary embodiment, radially expanding the overlap between the first and second tubular members further includes displacing the second expansion cone in a longitudinal direction, and permitting fluidic materials displaced by the second expansion cone to be removed. In an exemplary embodiment, displacing the second expansion cone in a longitudinal direction includes applying fluid pressure to the second expansion cone. In an exemplary embodiment, radially expanding the overlap between the first and second tubular members further includes displacing the second expansion cone in a longitudinal direction, and compressing at least a portion of the subterranean formation using fluid pressure. In an exemplary embodiment, displacing the second expansion cone in a longitudinal direction includes applying fluid pressure to the second expansion cone. In an exemplary embodiment, radially expanding the portion of the second tubular member that does not overlap with the first tubular members using the second expansion cone includes displacing the second expansion cone in a longitudinal direction, and permitting fluidic materials displaced by the second expansion cone to be removed. In an exemplary embodiment, displacing the second expansion cone in the longitudinal direction includes applying fluid pressure to the second expansion cone.

Although illustrative embodiments of the invention have been shown and described, a wide range of modification, changes and substitution is contemplated in the foregoing disclosure. In some instances, some features of the present invention may be employed without a corresponding use of the other features. Accordingly, it is appropriate that the appended claims be construed broadly and in a manner consistent with the scope of the invention.

20

## Claims

1. A method of creating a mono-diameter wellbore casing in a borehole located in a subterranean formation including a preexisting wellbore casing, comprising:  
5 installing a tubular liner and a first expansion cone in the borehole;  
injecting a fluidic material into the borehole;  
pressurizing a portion of an interior region of the tubular liner below the first expansion cone;  
radially expanding at least a portion of the tubular liner in the borehole by extruding at least a portion of  
the tubular liner off of the first expansion cone;  
10 radially expanding an overlap between the preexisting wellbore casing and the tubular liner; and  
radially expanding the portion of the tubular liner that does not overlap with the preexisting wellbore  
casing using a second expansion cone.
2. The method of claim 1, wherein radially expanding the overlap between the preexisting wellbore casing  
15 and the tubular liner comprises:  
impulsively applying outwardly directed radial forces to the interior of the overlap between the  
preexisting wellbore casing and the tubular liner.
3. The method of claim 2, wherein impulsively applying outwardly directed radial forces to the interior of  
20 the overlap between the preexisting wellbore casing and the tubular liner, comprises:  
detonating a shaped charge within the overlap between the preexisting wellbore casing and the tubular  
liner.
4. The method of claim 2, wherein radially expanding the overlap between the preexisting wellbore casing  
and the tubular liner further comprises:  
25 displacing the second expansion cone in a longitudinal direction; and  
permitting fluidic materials displaced by the second expansion cone to be removed.
5. The method of claim 4, wherein displacing the second expansion cone in a longitudinal direction  
comprises:  
30 applying fluid pressure to the second expansion cone.
6. The method of claim 2, wherein radially expanding the overlap between the tubular liner and the  
preexisting wellbore casing using the second expansion cone further comprises:  
displacing the second expansion cone in a longitudinal direction; and  
35 compressing at least a portion of the subterranean formation using fluid pressure.
7. The method of claim 6, wherein displacing the second expansion cone in a longitudinal direction  
comprises:  
applying fluid pressure to the second expansion cone.

8. The method of claim 1, wherein radially expanding the portion of the tubular liner that does not overlap with the preexisting wellbore casing using the second expansion cone comprises:  
5 displacing the second expansion cone in a longitudinal direction; and  
permitting fluidic materials displaced by the second expansion cone to be removed.
9. The method of claim 8, wherein displacing the second expansion cone in the longitudinal direction comprises:  
10 applying fluid pressure to the second expansion cone.
10. The method of claim 1, wherein radially expanding the portion of the tubular liner that does not overlap with the preexisting wellbore casing using the second expansion cone comprises:  
15 displacing the second expansion cone in a longitudinal direction; and  
compressing at least a portion of the subterranean formation using fluid pressure.
11. The method of claim 10, wherein displacing the second expansion cone in the longitudinal direction comprises:  
20 applying fluid pressure to the second expansion cone.
12. The method of claim 1, further comprising:  
25 injecting a hardenable fluidic sealing material into an annulus between the tubular liner and the borehole.
13. A system for creating a mono-diameter wellbore casing in a borehole located in a subterranean formation including a preexisting wellbore casing, comprising:  
25 means for installing a tubular liner and a first expansion cone in the borehole;  
means for injecting a fluidic material into the borehole;  
means for pressurizing a portion of an interior region of the tubular liner below the first expansion cone;  
30 means for radially expanding at least a portion of the tubular liner in the borehole by extruding at least a portion of the tubular liner off of the first expansion cone;  
means for radially expanding an overlap between the preexisting wellbore casing and the tubular liner;  
35 and  
means for radially expanding the portion of the tubular liner that does not overlap with the preexisting wellbore casing using a second expansion cone.
14. The system of claim 13, wherein the means for radially expanding the overlap between the preexisting wellbore casing and the tubular liner comprises:  
means for impulsively applying outwardly directed radial forces to the interior of the overlap between  
the preexisting wellbore casing and the tubular liner.



15. The system of claim 14, wherein the means for impulsively applying outwardly directed radial forces to the interior of the overlap between the preexisting wellbore casing and the tubular liner, comprises:  
means for detonating a shaped charge within the overlap between the preexisting wellbore casing and  
5 the tubular liner.
16. The system of claim 14, wherein the means for radially expanding the overlap between the preexisting wellbore casing and the tubular liner further comprises:  
displacing the second expansion cone in a longitudinal direction; and  
10 permitting fluidic materials displaced by the second expansion cone to be removed.
17. The system of claim 16, wherein the means for displacing the second expansion cone in a longitudinal direction comprises:  
means for applying fluid pressure to the second expansion cone.  
15
18. The system of claim 14, wherein the means for radially expanding the overlap between the tubular liner and the preexisting wellbore casing using the second expansion cone further comprises:  
means for displacing the second expansion cone in a longitudinal direction; and  
means for compressing at least a portion of the subterranean formation using fluid pressure.  
20
19. The system of claim 18, wherein the means for displacing the second expansion cone in a longitudinal direction comprises:  
means for applying fluid pressure to the second expansion cone.
- 25 20. The system of claim 13, wherein the means for radially expanding the portion of the tubular liner that does not overlap with the preexisting wellbore casing using the second expansion cone comprises:  
means for displacing the second expansion cone in a longitudinal direction; and  
means for permitting fluidic materials displaced by the second expansion cone to be removed.
- 30 21. The system of claim 20, wherein the means for displacing the second expansion cone in the longitudinal direction comprises:  
means for applying fluid pressure to the second expansion cone.
22. The system of claim 13, wherein the means for radially expanding the portion of the tubular liner that  
35 does not overlap with the preexisting wellbore casing using the second expansion cone comprises:  
means for displacing the second expansion cone in a longitudinal direction; and  
means for compressing at least a portion of the subterranean formation using fluid pressure.

23. The system of claim 22, wherein the means for displacing the second expansion cone in the longitudinal direction comprises:  
means for applying fluid pressure to the second expansion cone.
- 5 24. The system of claim 13, further comprising:  
means for injecting a hardenable fluidic sealing material into an annulus between the tubular liner and the borehole.
- 10 25. A method of creating a tubular structure having a substantially constant inside diameter, comprising:  
installing a first tubular member and a first expansion cone within a second tubular member;  
injecting a fluidic material into the second tubular member;  
pressurizing a portion of an interior region of the first tubular member below the first expansion cone;  
radially expanding at least a portion of the first tubular member in the second tubular member by  
extruding at least a portion of the first tubular member off of the first expansion cone;  
15 radially expanding an overlap between the first and second tubular members; and  
radially expanding the portion of the first tubular member that does not overlap with the second tubular member using a second expansion cone.
- 20 26. The method of claim 25, wherein radially expanding the overlap between the first and second tubular members comprises:  
impulsively applying outwardly directed radial forces to the interior of the overlap between the first and second tubular members.
- 25 27. The method of claim 26, wherein impulsively applying outwardly directed radial forces to the interior of the overlap between the first and second tubular members, comprises:  
detonating a shaped charge within the overlap between the first and second tubular members.
- 30 28. The method of claim 26, wherein radially expanding the overlap between the first and second tubular members further comprises:  
displacing the second expansion cone in a longitudinal direction; and  
permitting fluidic materials displaced by the second expansion cone to be removed.
- 35 29. The method of claim 28, wherein displacing the second expansion cone in a longitudinal direction comprises:  
applying fluid pressure to the second expansion cone.
30. The method of claim 26, wherein radially expanding the overlap between the first and second tubular members using the second expansion cone further comprises:  
displacing the second expansion cone in a longitudinal direction; and

compressing at least a portion of the subterranean formation using fluid pressure.

31. The method of claim 30, wherein displacing the second expansion cone in a longitudinal direction comprises:

5 applying fluid pressure to the second expansion cone.

32. The method of claim 25, wherein radially expanding the portion of the first tubular member that does not overlap with the second tubular member using the second expansion cone comprises:

10 displacing the second expansion cone in a longitudinal direction; and  
permitting fluidic materials displaced by the second expansion cone to be removed.

33. The method of claim 32, wherein displacing the second expansion cone in the longitudinal direction comprises:

15 applying fluid pressure to the second expansion cone.

34. A system for creating a tubular structure having a substantially constant inside diameter, comprising:

20 means for installing a first tubular member and a first expansion cone within a second tubular member;  
means for injecting a fluidic material into the second tubular member;  
means for pressurizing a portion of an interior region of the first tubular member below the first  
expansion cone;  
means for radially expanding at least a portion of the first tubular member in the second tubular member  
by extruding at least a portion of the first tubular member off of the first expansion cone;  
means for radially expanding an overlap between the first and second tubular members; and  
means for radially expanding the portion of the first tubular member that does not overlap with the  
25 second tubular member using a second expansion cone.

35. The system of claim 34, wherein the means for radially expanding the overlap between the first and second tubular members comprises:

30 means for impulsively applying outwardly directed radial forces to the interior of the overlap between  
the first and second tubular members.

36. The system of claim 35, wherein the means for impulsively applying outwardly directed radial forces to the interior of the overlap between the first and second tubular members, comprises:

means for detonating a shaped charge within the overlap between the first and second tubular members.

37. The system of claim 35, wherein the means for radially expanding the overlap between the first and second tubular members further comprises:

means for displacing the second expansion cone in a longitudinal direction; and  
means for permitting fluidic materials displaced by the second expansion cone to be removed.

38. The system of claim 37, wherein the means for displacing the second expansion cone in a longitudinal direction comprises:  
means for applying fluid pressure to the second expansion cone.
- 5 39. The system of claim 35, wherein the means for radially expanding the overlap between the first and second tubular members using the second expansion cone further comprises:  
means for displacing the second expansion cone in a longitudinal direction; and  
means for compressing at least a portion of the subterranean formation using fluid pressure.
- 10 40. The system of claim 39, wherein the means for displacing the second expansion cone in a longitudinal direction comprises:  
means for applying fluid pressure to the second expansion cone.
41. The system of claim 34, wherein the means for radially expanding the portion of the first tubular  
15 member that does not overlap with the second tubular member using the second expansion cone comprises:  
means for displacing the second expansion cone in a longitudinal direction; and  
means for permitting fluidic materials displaced by the second expansion cone to be removed.
42. The system of claim 41, wherein the means for displacing the second expansion cone in the longitudinal  
20 direction comprises:  
means for applying fluid pressure to the second expansion cone.
43. An apparatus, comprising:  
a subterranean formation including a borehole;  
25 a wellbore casing coupled to the borehole; and  
a tubular liner overlappingly coupled to the wellbore casing;  
wherein the inside diameter of the portion of the wellbore casing that does not overlap with the tubular  
liner is substantially equal to the inside diameter of the tubular liner; and  
wherein the tubular liner is coupled to the wellbore casing by a method comprising:  
30 installing the tubular liner and a first expansion cone in the borehole;  
injecting a fluidic material into the borehole;  
pressurizing a portion of an interior region of the tubular liner below the first expansion cone;  
radially expanding at least a portion of the tubular liner in the borehole by extruding at least a  
portion of the tubular liner off of the first expansion cone;  
35 radially expanding an overlap between the wellbore casing and the tubular liner; and  
radially expanding the portion of the tubular liner that does not overlap with the wellbore  
casing using a second expansion cone.

44. The apparatus of claim 43, wherein radially expanding the overlap between the preexisting wellbore casing and the tubular liner comprises:

impulsively applying outwardly directed radial forces to the interior of the overlap between the wellbore casing and the tubular liner.

5

45. The apparatus of claim 44, wherein impulsively applying outwardly directed radial forces to the interior of the overlap between the wellbore casing and the tubular liner, comprises:

detonating a shaped charge within the overlap between the wellbore casing and the tubular liner.

10

46. The apparatus of claim 44, wherein radially expanding the overlap between the wellbore casing and the tubular liner further comprises:

displacing the second expansion cone in a longitudinal direction; and  
permitting fluidic materials displaced by the second expansion cone to be removed.

15

47. The apparatus of claim 46, wherein displacing the second expansion cone in a longitudinal direction comprises:

applying fluid pressure to the second expansion cone.

20

48. The apparatus of claim 44, wherein radially expanding the overlap between the tubular liner and the wellbore casing using the second expansion cone further comprises:

displacing the second expansion cone in a longitudinal direction; and  
compressing at least a portion of the subterranean formation using fluid pressure.

25

49. The apparatus of claim 48, wherein displacing the second expansion cone in a longitudinal direction comprises:

applying fluid pressure to the second expansion cone.

30

50. The apparatus of claim 43, wherein radially expanding the portion of the tubular liner that does not overlap with the wellbore casing using the second expansion cone comprises:

displacing the second expansion cone in a longitudinal direction; and  
permitting fluidic materials displaced by the second expansion cone to be removed.

35

51. The apparatus of claim 50, wherein displacing the second expansion cone in the longitudinal direction comprises:

applying fluid pressure to the second expansion cone.

52. The apparatus of claim 43, wherein radially expanding the portion of the tubular liner that does not overlap with the wellbore casing using the second expansion cone comprises:

displacing the second expansion cone in a longitudinal direction; and

compressing at least a portion of the subterranean formation using fluid pressure.

53. The apparatus of claim 52, wherein displacing the second expansion cone in the longitudinal direction comprises:

5 applying fluid pressure to the second expansion cone.

54. The apparatus of claim 43, further comprising:

injecting a hardenable fluidic sealing material into an annulus between the tubular liner and the borehole.

10

55. An apparatus, comprising:

a first tubular member; and

a second tubular member overlappingly coupled to the first tubular member;

wherein the inside diameter of the portion of the first tubular member that does not overlap with the second tubular member is substantially equal to the inside diameter of the second tubular member; and

15

wherein the second tubular member is coupled to the first tubular member by a method comprising: installing the second tubular member and a first expansion cone in the first tubular member; injecting a fluidic material into the first tubular member;

20

pressurizing a portion of an interior region of the second tubular member below the first expansion cone;

radially expanding at least a portion of the second tubular member in the first tubular member

by extruding at least a portion of the tubular liner off of the first expansion cone;

radially expanding an overlap between the first and second tubular members; and

25

radially expanding the portion of the second tubular member that does not overlap with the first tubular member using a second expansion cone.

56. The apparatus of claim 55, wherein radially expanding the overlap between the first and second tubular members comprises:

30

impulsively applying outwardly directed radial forces to the interior of the overlap between the first and second tubular members.

57. The apparatus of claim 56, wherein impulsively applying outwardly directed radial forces to the interior of the overlap between the first and second tubular members, comprises:

35

detonating a shaped charge within the overlap between the first and second tubular members.

58. The apparatus of claim 56, wherein radially expanding the overlap between the first and second tubular members further comprises:

displacing the second expansion cone in a longitudinal direction; and

permitting fluidic materials displaced by the second expansion cone to be removed.

59. The apparatus of claim 58, wherein displacing the second expansion cone in a longitudinal direction comprises:

5 applying fluid pressure to the second expansion cone.

60. The apparatus of claim 56, wherein radially expanding the overlap between the first and second tubular members further comprises:

10 displacing the second expansion cone in a longitudinal direction; and  
compressing at least a portion of the subterranean formation using fluid pressure.

61. The apparatus of claim 60, wherein displacing the second expansion cone in a longitudinal direction comprises:

15 applying fluid pressure to the second expansion cone.

62. The apparatus of claim 55, wherein radially expanding the portion of the second tubular member that does not overlap with the first tubular members using the second expansion cone comprises:

20 displacing the second expansion cone in a longitudinal direction; and  
permitting fluidic materials displaced by the second expansion cone to be removed.

63. The apparatus of claim 62, wherein displacing the second expansion cone in the longitudinal direction comprises:

25 applying fluid pressure to the second expansion cone.

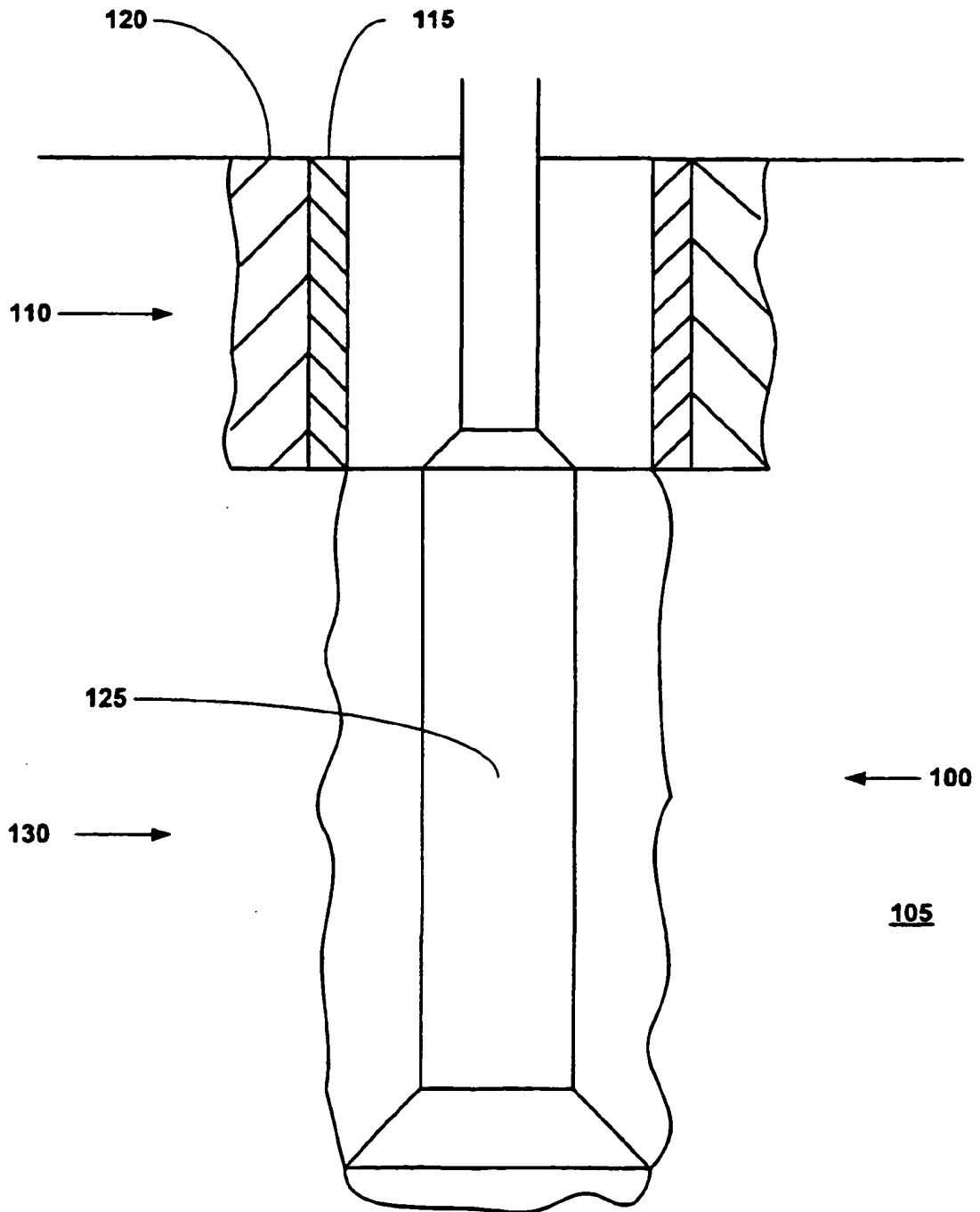

FIGURE 1



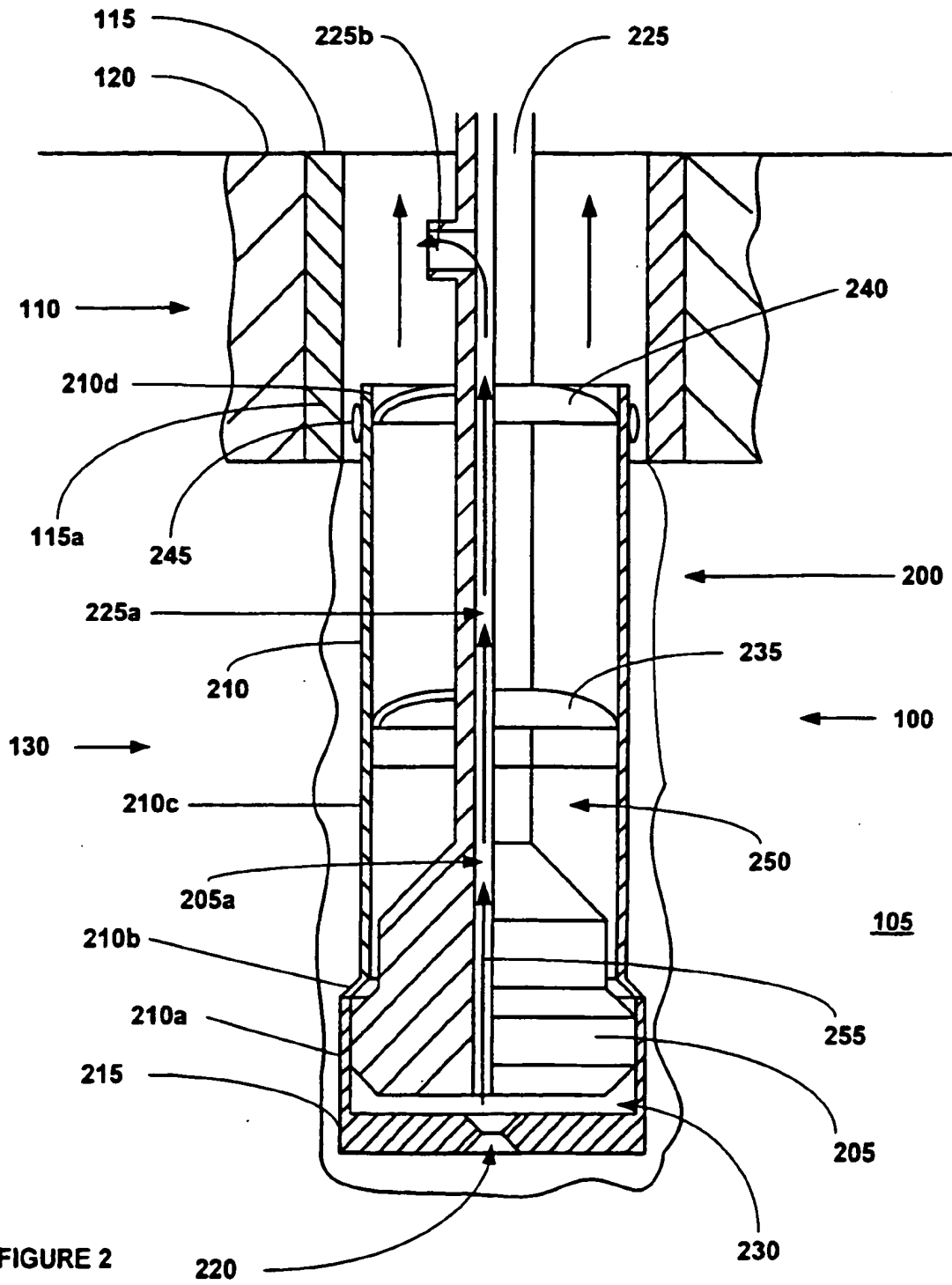

FIGURE 2

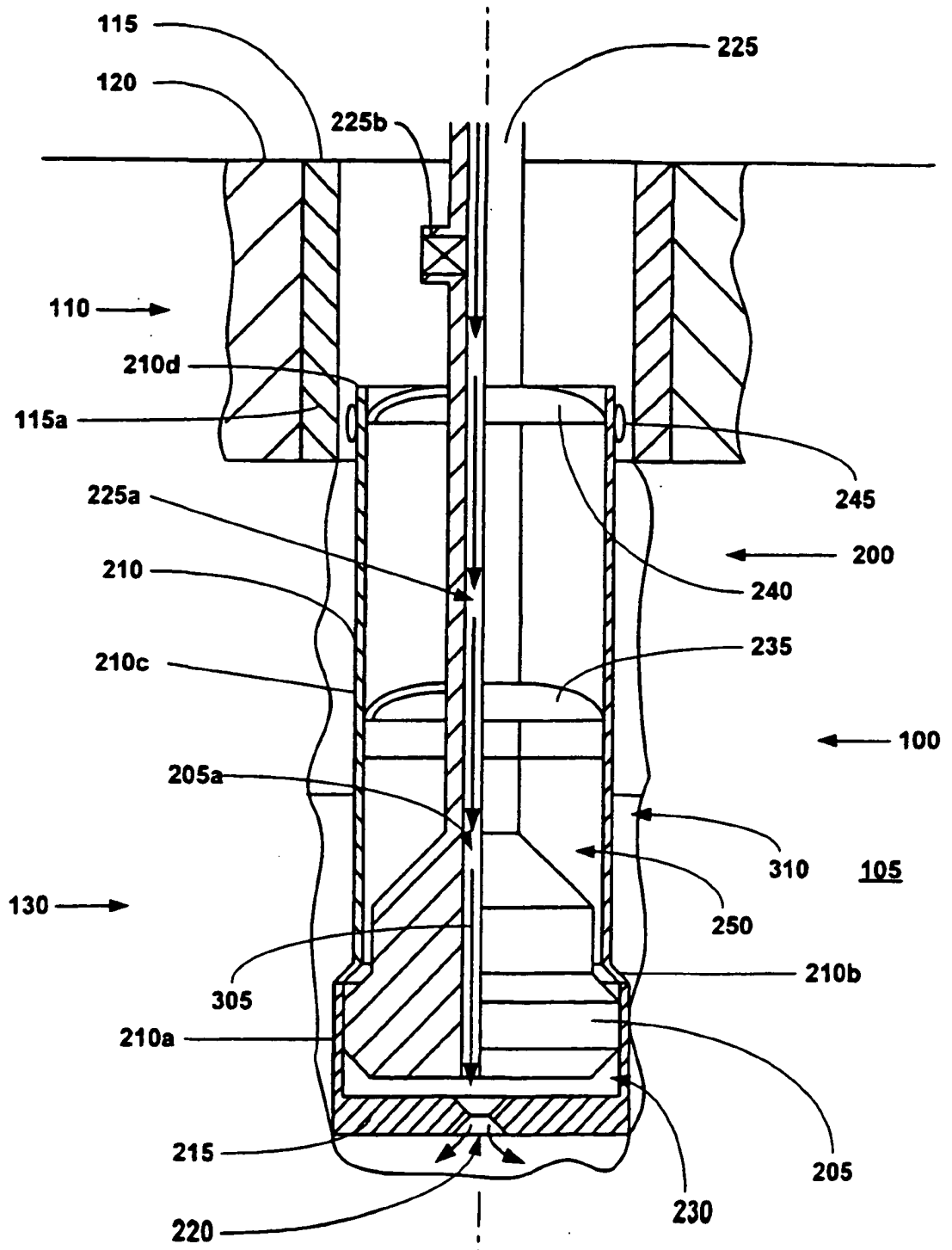

FIGURE 3

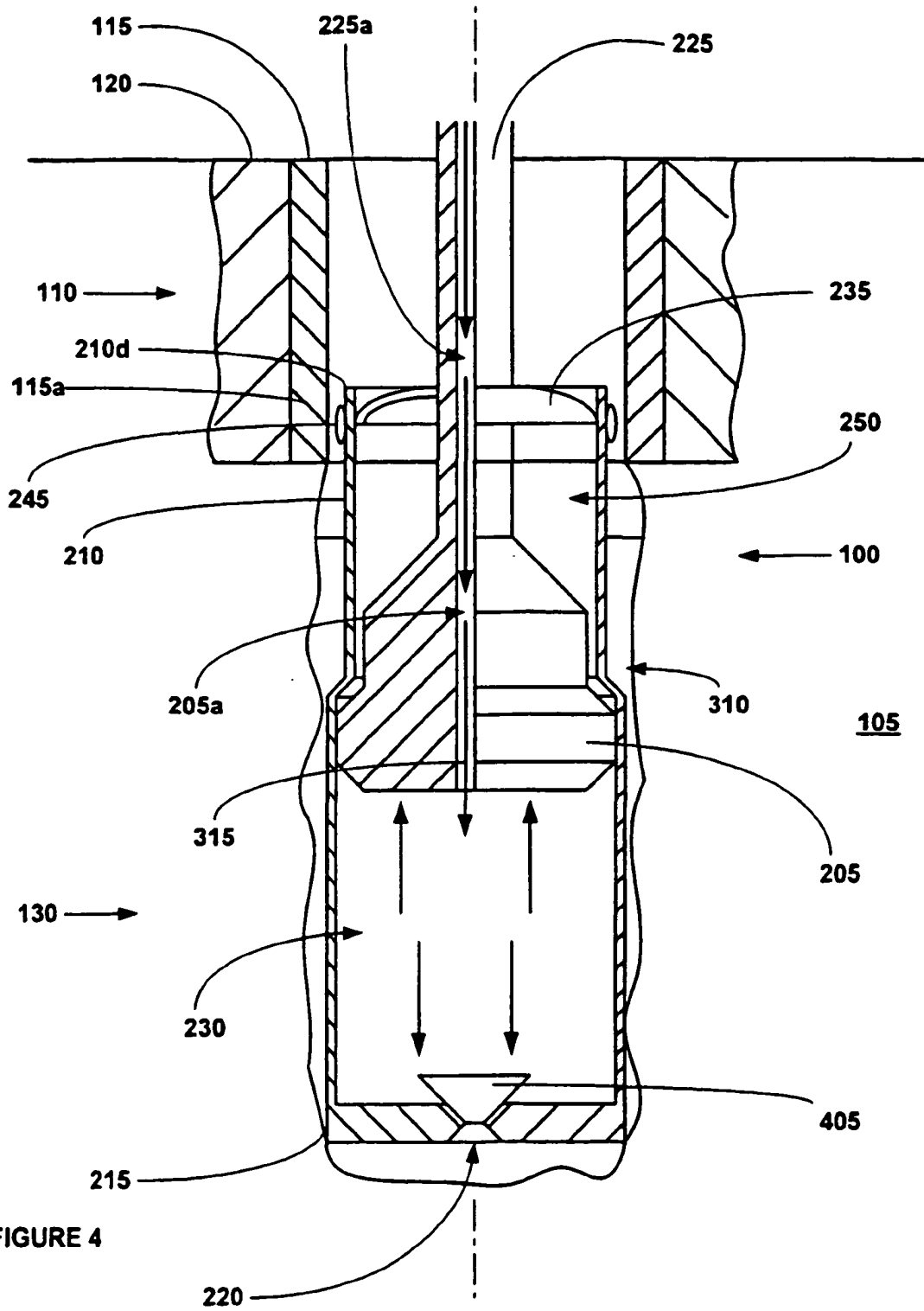

FIGURE 4

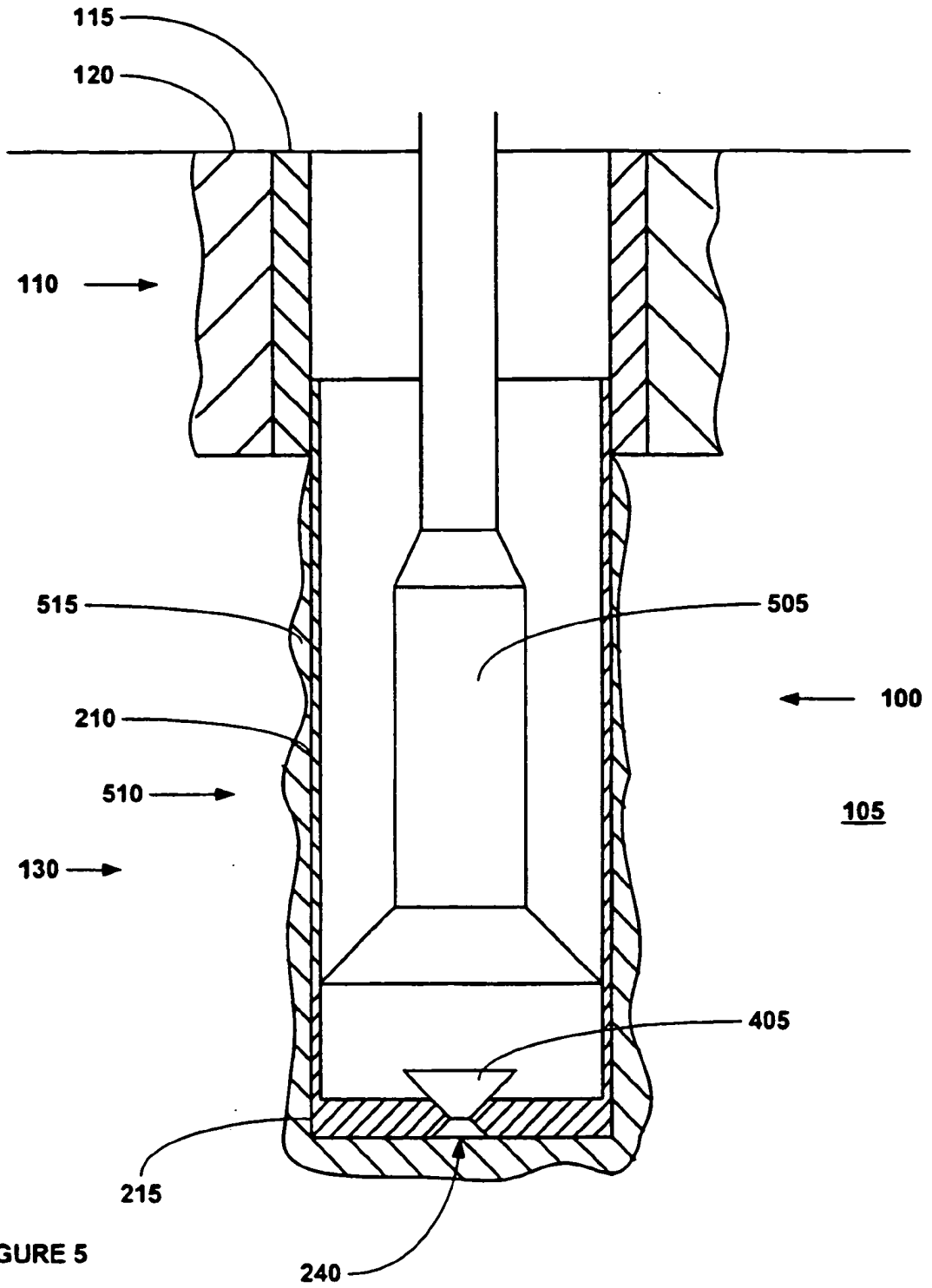

FIGURE 5



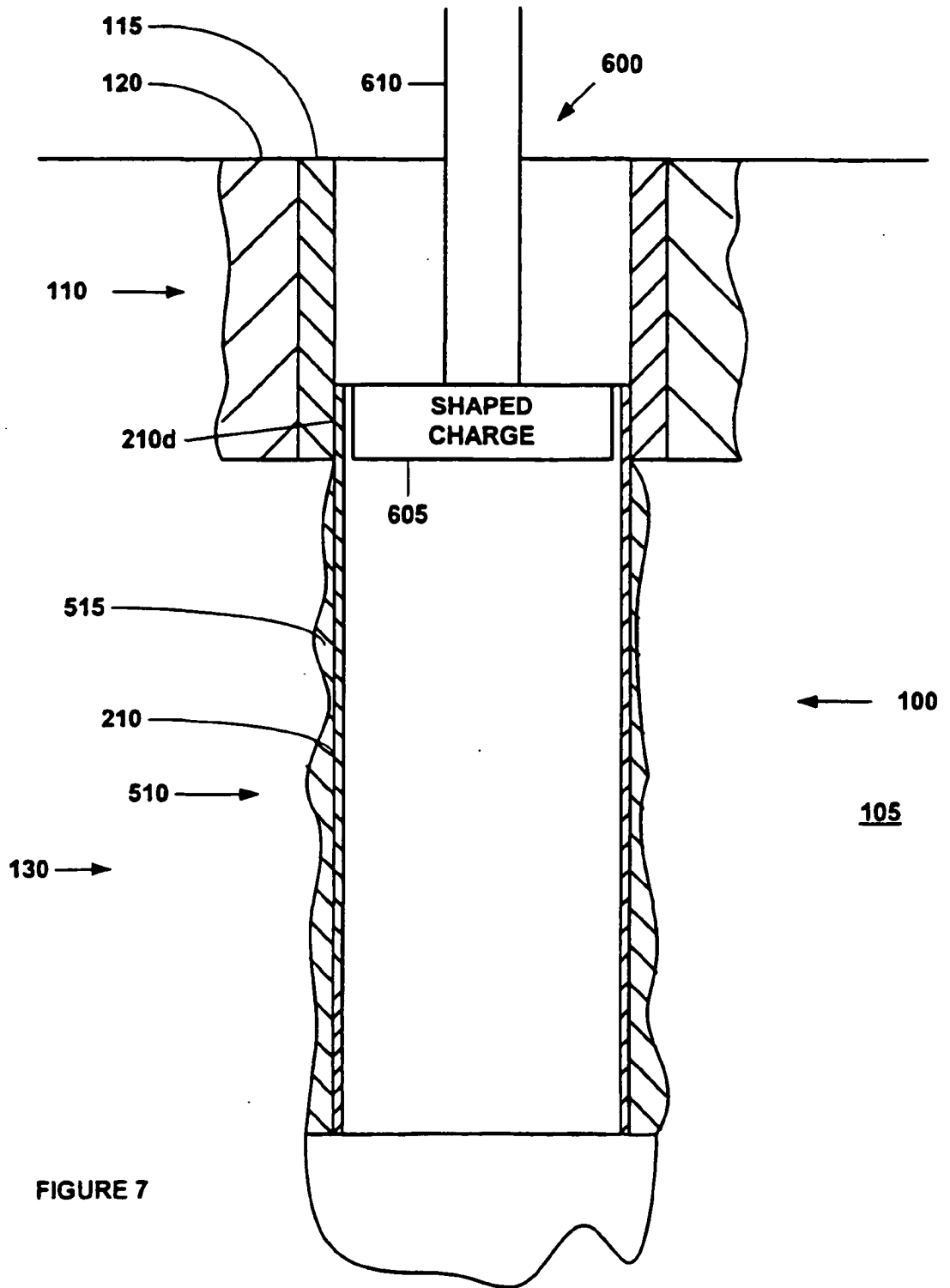

FIGURE 7

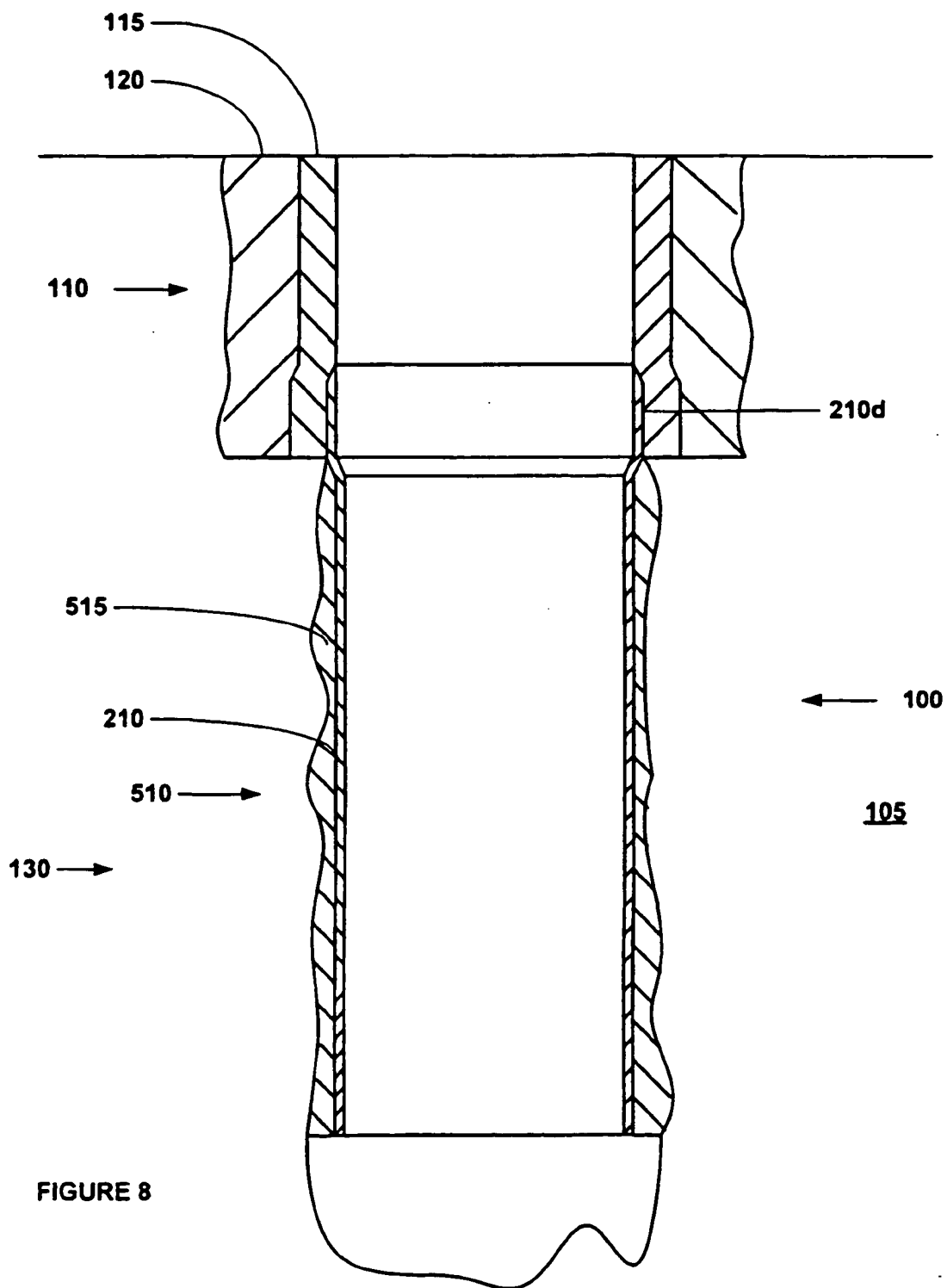

FIGURE 8

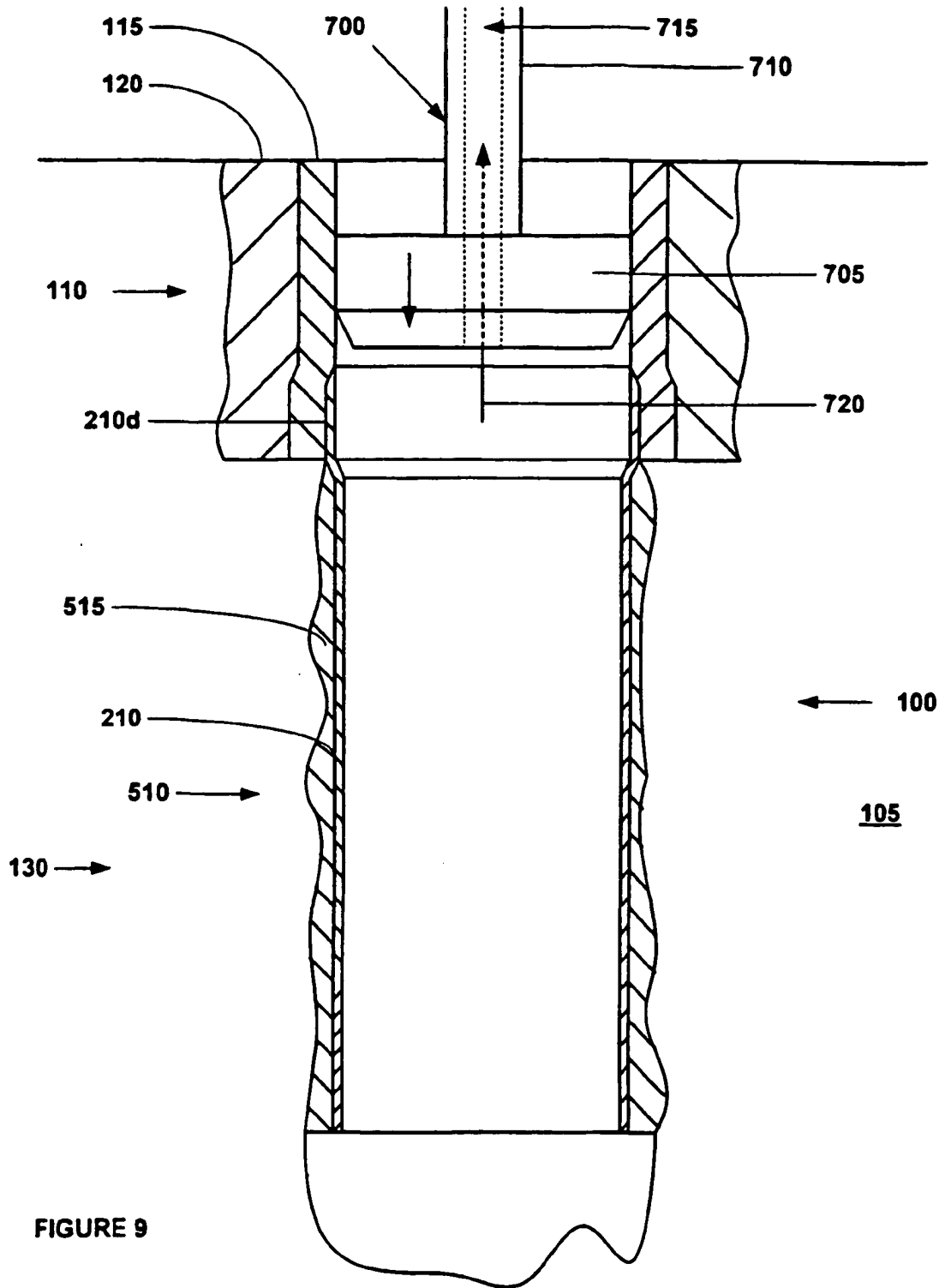

FIGURE 9



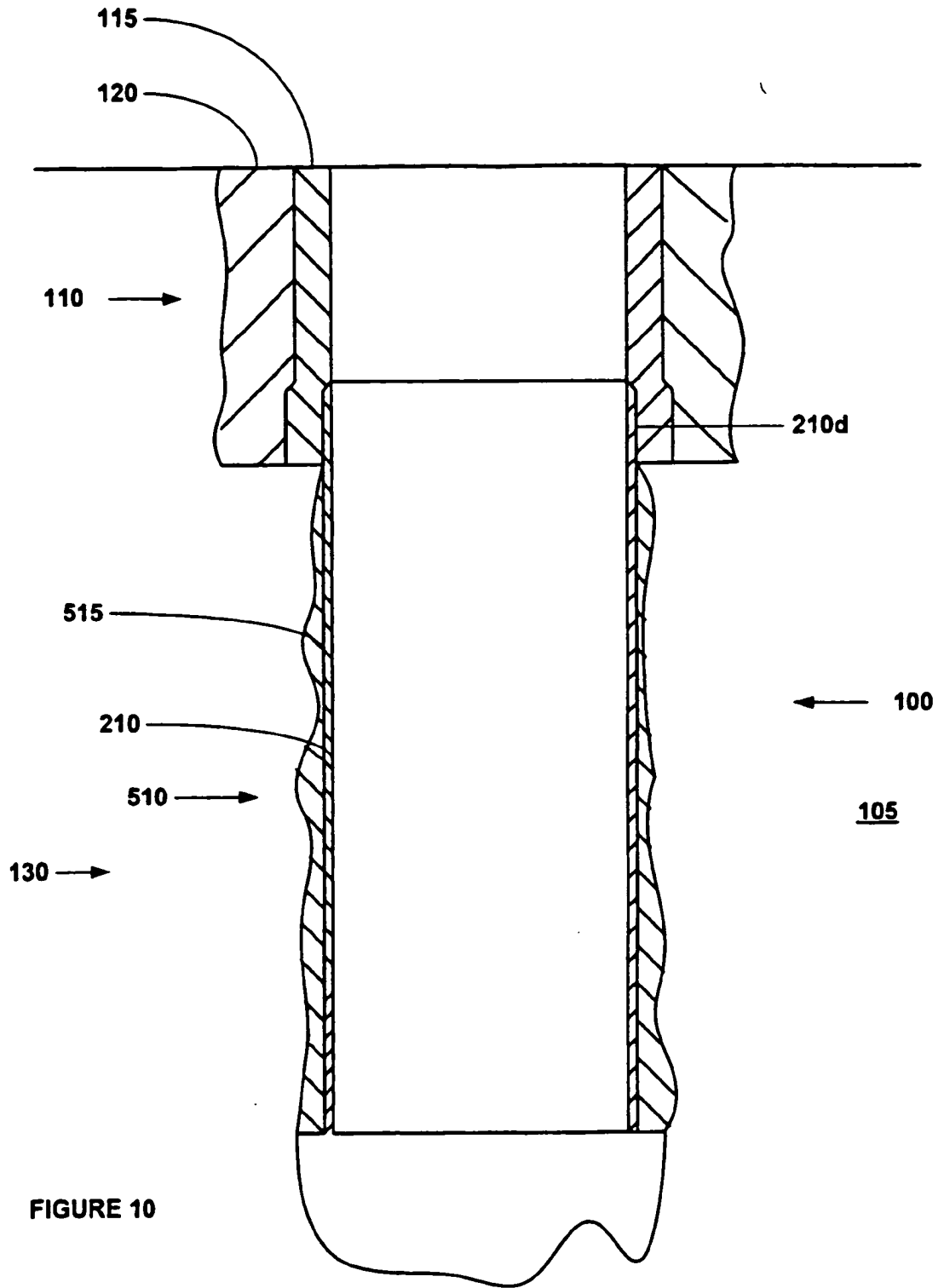

FIGURE 10

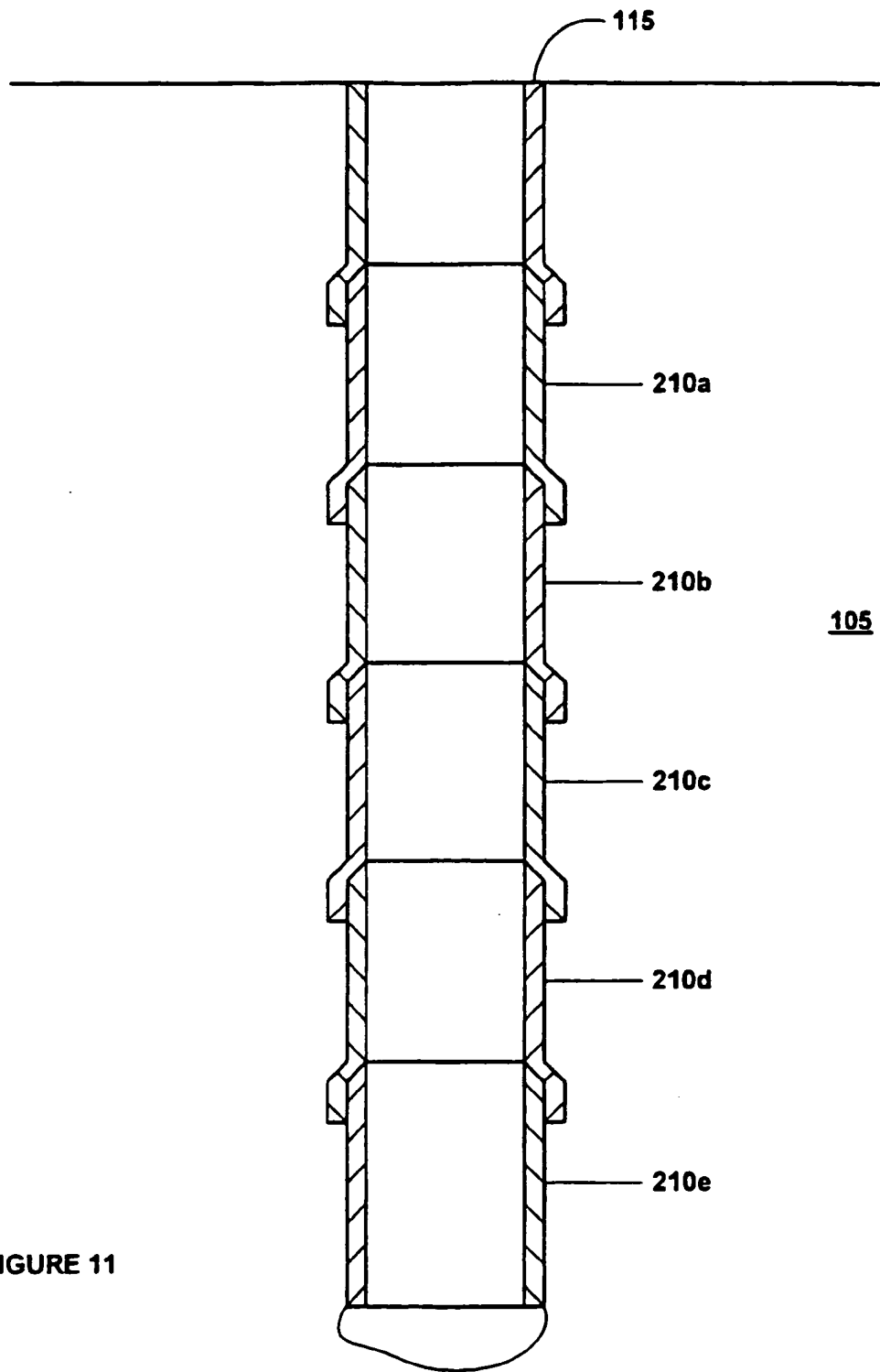

FIGURE 11

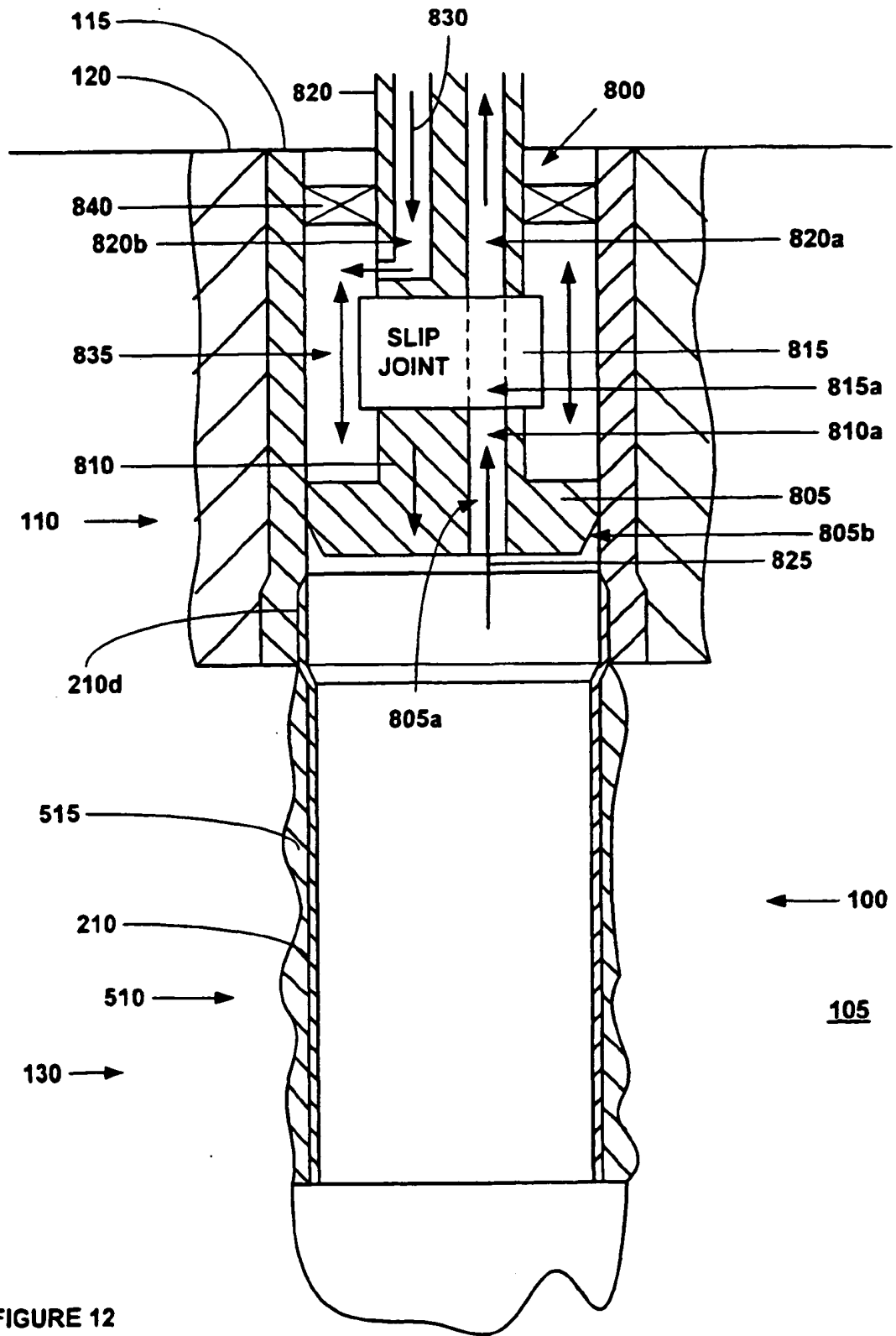

FIGURE 12





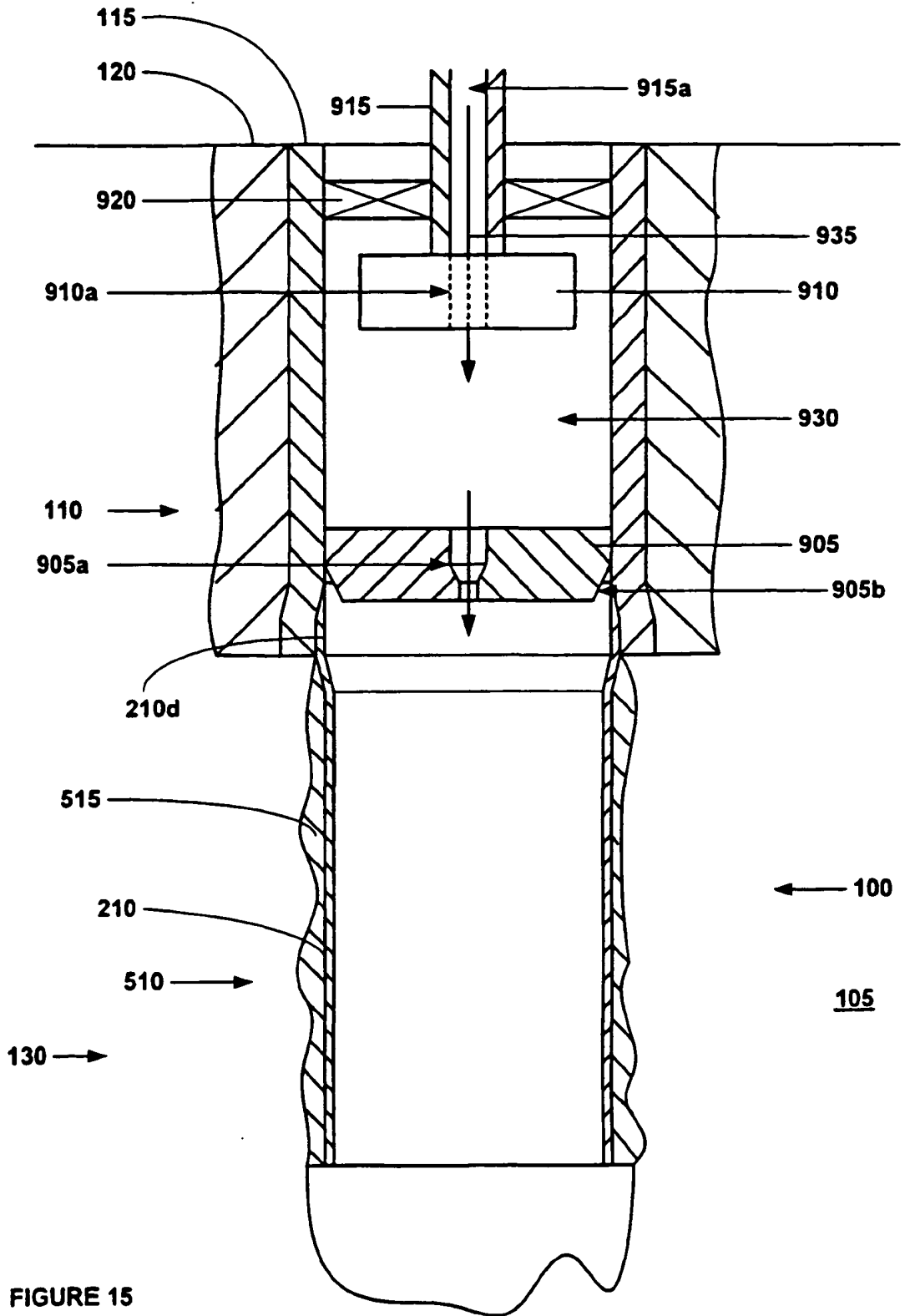

FIGURE 15

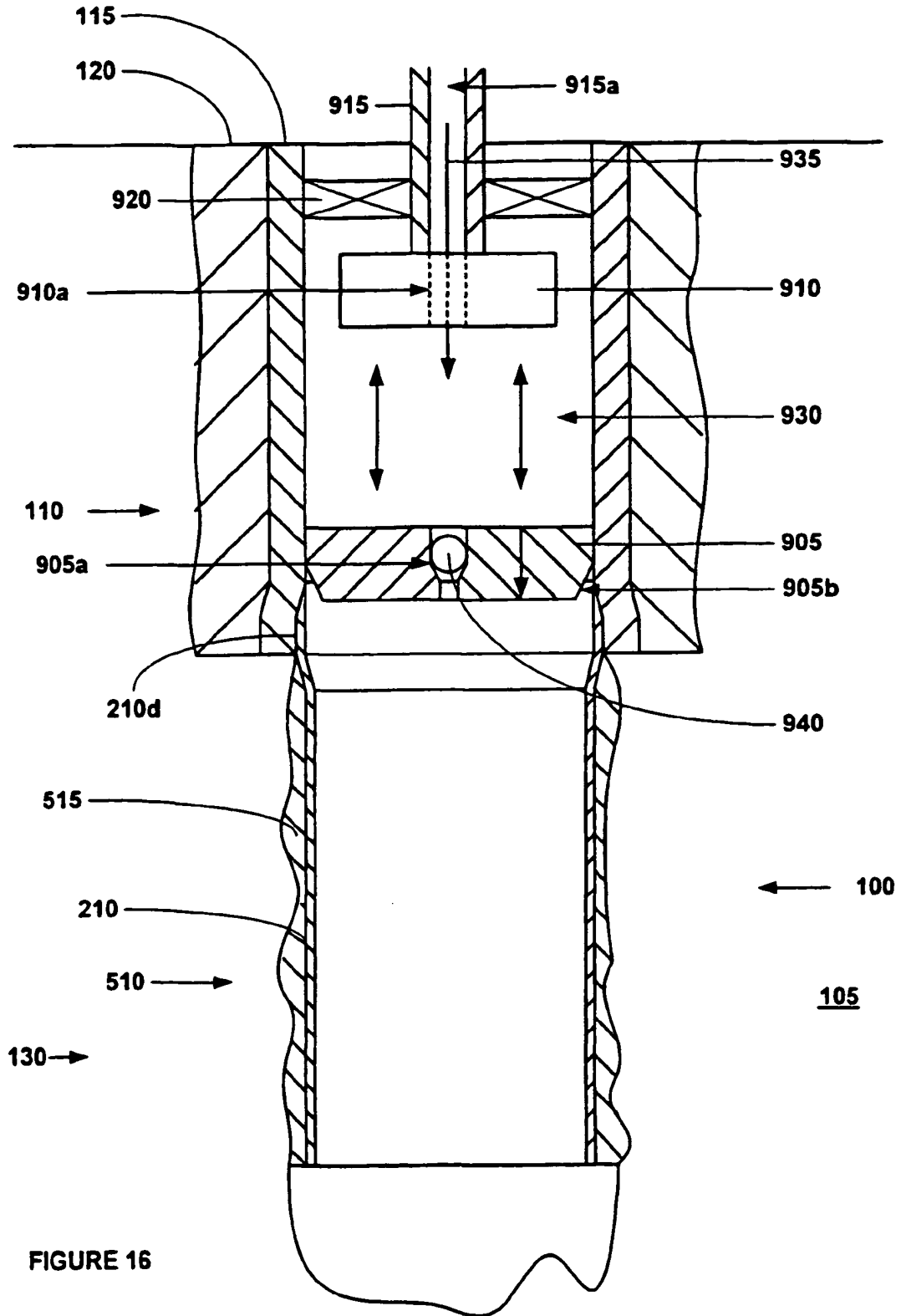

FIGURE 16

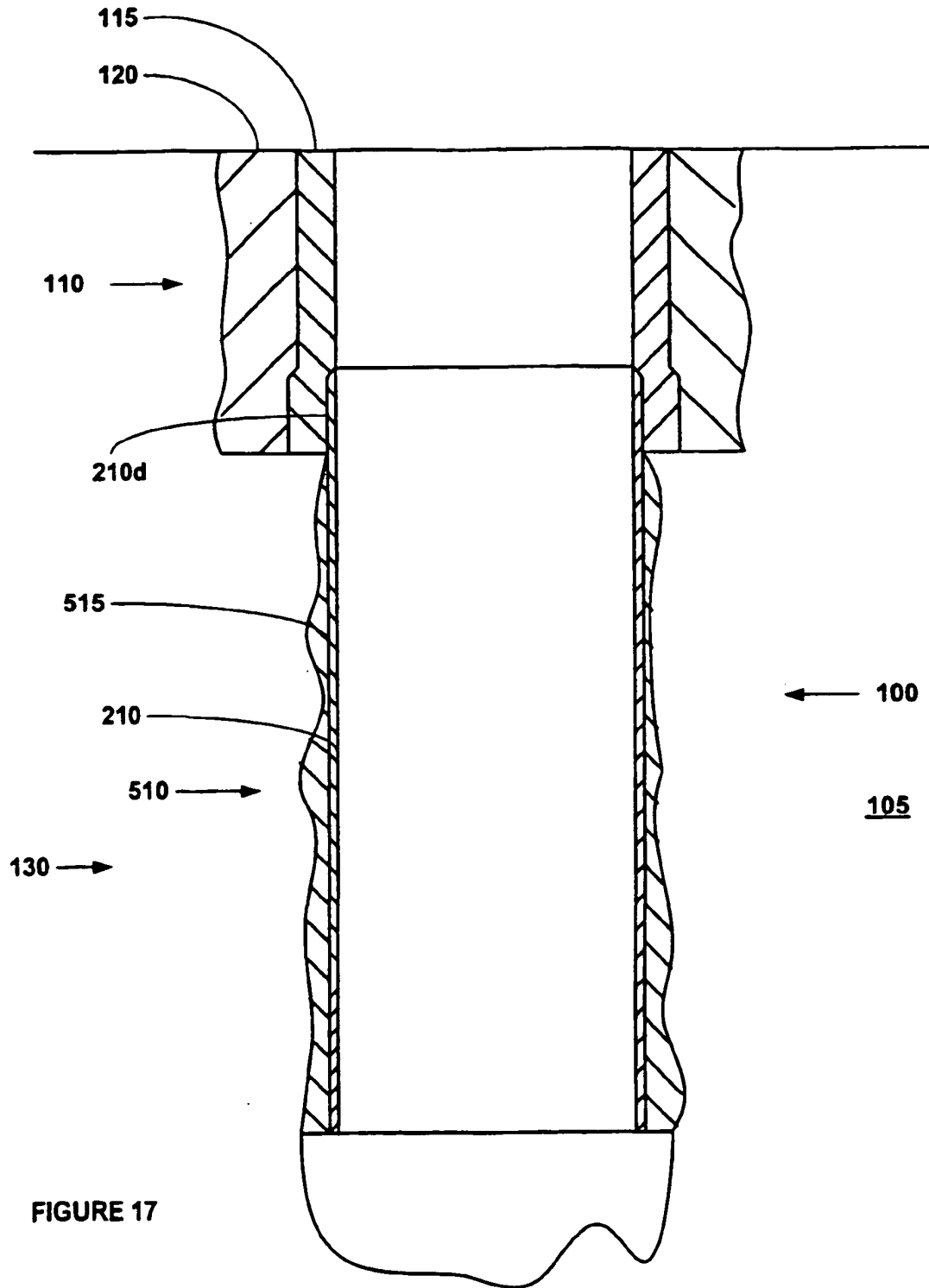

FIGURE 17



**INTERNATIONAL SEARCH REPORT**

International application No.

PCT/US02/29856

**A. CLASSIFICATION OF SUBJECT MATTER**

IPC(7) : E21B 19/16, 43/10  
 US CL : 166/380, 207

According to International Patent Classification (IPC) or to both national classification and IPC

**B. FIELDS SEARCHED**

Minimum documentation searched (classification system followed by classification symbols)  
 U.S. : 166/380, 207, 378, 206, 216, 217

Documentation searched other than minimum documentation to the extent that such documents are included in the fields searched

Electronic data base consulted during the international search (name of data base and, where practicable, search terms used)

**C. DOCUMENTS CONSIDERED TO BE RELEVANT**

Category *	Citation of document, with indication, where appropriate, of the relevant passages	Relevant to claim No.
A	US 6,085,838 A (VERCAEMER et al.) 11 July 2000 (11 07, 2000), figures 5-7.	1-6,3

Further documents are listed in the continuation of Box C.

See patent family annex.

Special categories of cited documents	Symbol	Description
"A" document defining the general state of the art which is not considered to be of particular relevance	"A"	later document published after the international filing date or priority date and not in conflict with the application but cited to understand the principle or theory underlying the invention
"E" earlier application or patent published on or after the international filing date	"E"	document of particular relevance - the claimed invention cannot be considered novel or cannot be considered to involve an inventive step when the document is taken into account
"L" document which may throw doubts on priority claim(s) or which is cited to establish the publication date of another citation or other special reason (as specified)	"L"	document of particular relevance - the candidate of the invention is considered to involve an inventive step when the document is taken into account
"O" document referring to an oral disclosure, use, exhibition or other means	"O"	document of particular relevance - the candidate of the invention is considered to involve an inventive step when the document is taken into account
"P" document published prior to the international filing date but later than the priority date claimed	"P"	document member of the same patent family

Date of the actual completion of the international search

08 November 2002 (08.11.2002)

Date of mailing of the international search report

16 DEC 2002

Name and mailing address of the ISA-US  
 Commissioner of Patents and Trademarks  
 Box PCT  
 Washington, D.C. 20231

Facsimile No. (703)305-3230

Authorized officer

David R. Smith, 11/16/02

Telephone No. (703) 308-1111